

## Connections

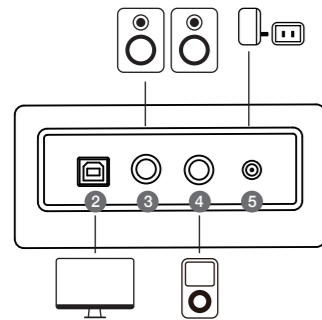
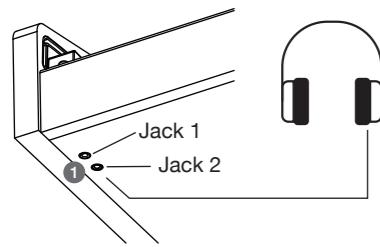

### 1. PHONE Jacks

For connecting to headphones.

When headphones are connected to Jack 1, the sound can be heard from the headphones and the speakers.

When headphones are connected to Jack 2, the internal speakers will be muted. The sound can only be heard from the headphones.

### 2. USB Jack

For connecting to a computer or a mobile device via cable. An additional adapter may be needed to connect to mobile devices.

This port supports transmitting/receiving both MIDI data and digital audio data. This instrument can be used to play back music played on the external device, or use the external device to record the performance from the instrument.

### 3. LINE OUT Jack

For connecting to the INPUT jack of external audio equipment such as a stereo sound system.

### 4. AUX IN Jack

For connecting to the OUTPUT jack of external audio source such as an MP3 player.

### 5. DC IN Jack

For connecting the specified power adapter.

#### Note:

Do not listen with the headphones at high volume for long periods of time. Doing so may harm your ear.

## Presets

### Sound List

1	Grand Piano	11	Church Organ
2	Grand Piano 2	12	Church Organ 2
3	Ele. Piano	13	Reed Organ
4	Ele. Piano 2	14	Rock Organ
5	Harpsichord	15	Accordion
6	Clavinet	16	Acoustic Guitar (Nylon)
7	Vibraphone	17	Acoustic Guitar (Steel)
8	Marimba	18	String Ensembles
9	Drawbar Organ	19	Synth Strings
10	Percussive Organ	20	Synth Strings 2

### Song List

1	Prelude and Fugue No.1 in C Major
2	Minuet in G Major (BWV Anh.114)
3	Fur Elise
4	Piano Sonate No.15 K.545 1st mov.
5	Gavotte
6	Minute Waltz, Op.64 No.1
7	Polonaise No.6 in A-Flat Major Op.53
8	Etude Op.25 No.1 in A-Flat Major
9	Salut d'Amour
10	Maple Leaf Rag

### Demo

Fantaisie-Impromptu

# MEDELI

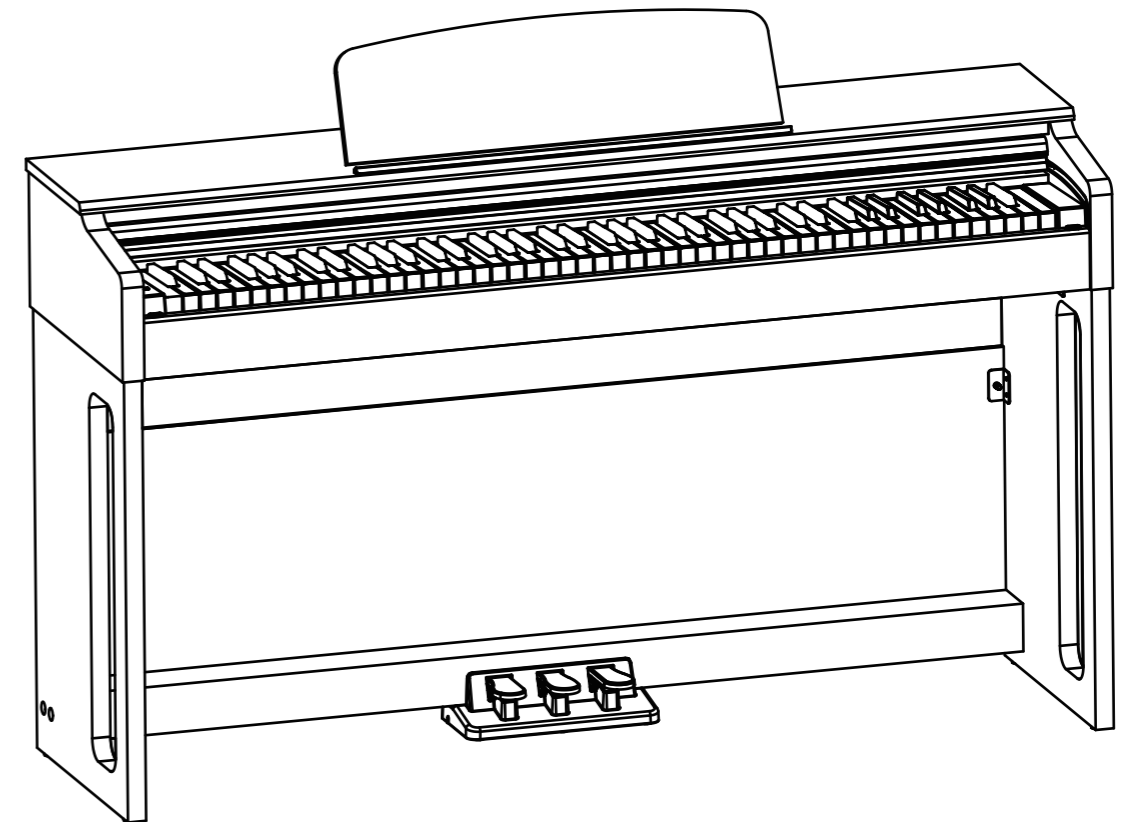

## UP82

UPRIGHT PIANO  
OWNER'S MANUAL



## THE FCC REGULATION WARNING (for the USA)

**NOTE:** This equipment has been tested and found to comply with the limits for a Class B digital device, pursuant to Part 15 of the FCC Rules. These limits are designed to provide reasonable protection against harmful interference in a residential installation. This equipment generates, uses, and can radiate radio frequency energy and, if not installed and used in accordance with the instructions, may cause harmful interference to radio communications. However, there is no guarantee that interference will not occur in a particular installation. If this equipment does cause harmful interference to radio or television reception, which can be determined by turning the equipment off and on, the user is encouraged to try to correct the interference by one or more of the following measures:

- Reorient or relocate the receiving antenna.
- Increase the separation between the equipment and receiver.
- Connect the equipment into an outlet on a circuit different from that to which the receiver is connected.
- Consult the dealer or an experienced radio/TV technician for help.

If items such as cables are included with this equipment, you must use those included items.

Unauthorized changes or modification to this system can void the user's authority to operate this equipment.

## CAUTION

The normal function of the product may be disturbed by Strong Electro Magnetic Interference. If so, simply reset the product to resume normal operation by following the owner's manual. In case the function could not resume, please use the product in other location.

### Keep this manual

After reading this manual, please keep it for later reference.

## PRECAUTIONS

### Location

Using the unit in the following locations can result in a malfunction.

- In direct sunlight
- Locations of extreme temperature or humidity
- Excessively dusty or dirty locations
- Locations of excessive vibration
- Close to magnetic fields

### Power Supply

Please connect the designated AC adapter to an AC outlet of the correct voltage.

Do not connect it to an AC outlet of voltage other than that for which your unit is intended.

### Interference with other electrical devices

Radios and televisions placed nearby may experience reception interference.

Operate this unit at a suitable distance from radios and televisions.

## Care

If the exterior becomes dirty, wipe it with a clean, dry cloth. Do not use liquid cleaners, such as benzene or thinner, or cleaning compounds or flammable polishes.

## Handling

To avoid breakage, do not apply excessive force to the switches or controls.

### Keeping foreign matter out of your equipment

Never set any container with liquid in it near this equipment. If liquid gets into the equipment, it could cause a breakdown, fire, or electrical shock. Be careful not to let metal objects get into the equipment.

## Troubleshooting

**The speakers produce a pop sound whenever the power is turned On/Off.**

This is normal and is no cause for alarm.

**Speakers do not produce sound when the keyboard is played.**

Check if the volume is set too low.

Check if headphones are plugged into PHONE Jack 2.

**When connecting to computer, the instrument cannot be recognized.**

Check if the USB cable is firmly connected. Try connecting another USB port on the computer. This instrument is plug and play which should work without installing a driver.

## Specifications

<b>Keyboard:</b>	88 Weighted, Graded Hammer Action
<b>Touch Response:</b>	5 Types, Off
<b>Polyphony:</b>	64 Notes (max.)
<b>Sound:</b>	20
<b>Layer:</b>	Left, Right 1, Right 2
<b>Sound Function:</b>	Layer, Split, Split Point
<b>Transpose:</b>	Yes, -12 ~ +12
<b>Twinova:</b>	Yes, -1 ~ +1 Octave Shift
<b>Tempo:</b>	30 ~ 280, Tap Tempo
<b>Metronome:</b>	Yes, 2 ~ 6 Types
<b>Effect:</b>	4 Reverb Types, D.A.S.
<b>Sound Demo:</b>	20
<b>Song:</b>	10
<b>Demo:</b>	1
<b>Other Functions:</b>	Beep Note, Auto Power Off
<b>Connectivity:</b>	2 Headphones, USB (USB-Audio & MIDI), Aux In, Line Out
<b>Pedal:</b>	Soft, Sostenuto, Sustain
<b>Power:</b>	DC 12V
<b>Amplifier:</b>	25 watt x 2
<b>Speaker:</b>	(15 x 10) cm x 2 oval
<b>Dimension (WDH):</b>	1369 x 398 x 813 mm
<b>Weight:</b>	41.2 kg

\*All specifications are subject to change without notice.

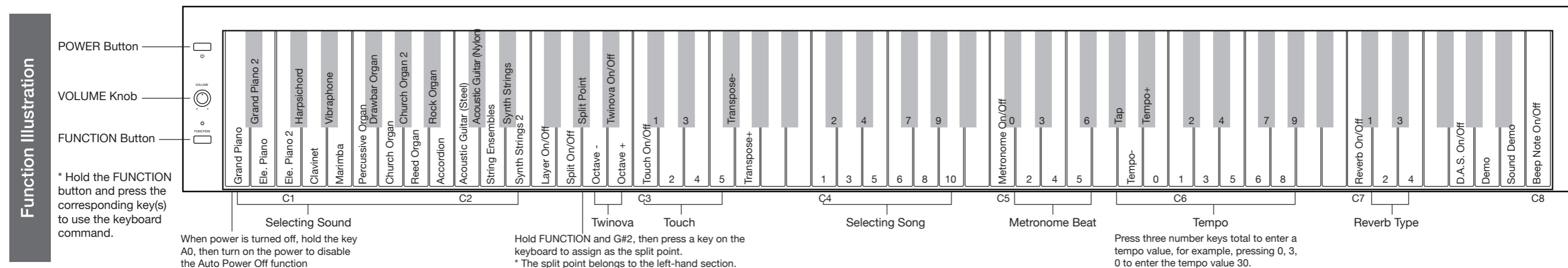

## Control Panel

POWER Button	Press to turn the power on or off.
VOLUME Knob	Rotate the knob clockwise or counter-clockwise to increase or decrease the volume level.
FUNCTION Button	Hold this button, then press the corresponding key(s) to use the keyboard command.



\*Key Names

## Keyboard Command

Selecting sound	A0 ~ E2	Select a sound as the upper sound.
Layer mode	F2	Turn the Layer mode on or off. You can layer two sounds. When in Layer mode, use the keyboard command to select a layer sound.
Split mode	G2	Turn the Split mode on or off. The keyboard is divided into left and right sections. When in Split mode, use the keyboard command to select a lower sound.
Split point	G#2 + a key	Hold FUNCTION and G#2, then press a key on the keyboard to assign the split point for Split mode.
Twinova function	Bb2	Turn Twinova function on or off. In Twinova mode, the keyboard is split into two sections with the same sound and octave range.
Twinova octave	A2 or B2	Adjust the octave of both the left and right sections in Twinova mode. Hold FUNCTION, then press A2 and B2 at the same time to reset to the default octave setting.
Touch response	C3	Turn touch response on or off. It is turned on by default.
Touch response level	C#3 ~ F3	Select a touch response level. The numbers 1 ~ 5 correspond to these response settings: Soft 1, Soft 2, Medium, Hard 1, and Hard 2.

Transpose	F#3 or G3	Shift the pitch of the entire keyboard up or down by a maximum of one octave in semitone steps. Hold FUNCTION, then press F#3 and G3 at the same time to reset to the default transpose setting.
Selecting song	C4 ~ A4	Start/stop playing song no. 1 ~ 10.
Metronome	C5	Turn the metronome on or off.
Metronome accent	C#5 ~ F#5	Set the metronome accent. For example, when selecting 0, no accent will play. When selecting 2, you will get an accent every two beats.
Tap	Ab5	Tap this key at an even speed to set the tempo.
Adjusting the tempo	A5 or Bb5	Increase or decrease the tempo value by the step of 1. Hold FUNCTION, then press A5 and Bb5 at the same time to reset to the default tempo.
Entering tempo value	B5 ~ Ab6	Press three number keys total to enter a tempo value. The range is 30~280. When entering a number lower than 30 or above 280, the instrument will set the tempo to 30 or 280.
Reverb	C7	Turn reverb on or off. It is turned on by default.
Reverb type	C#7 ~ E7	Select a reverb type. The numbers 1 ~ 4 correspond to these reverb types: Room, Hall 1, Hall 2, and Church.
D.A.S.	G7	Turn the D.A.S. on or off. It is turned on by default. The D.A.S. dynamically adjusts the sound of the instrument according to the overall volume for better sound balance.
Demo	A7	Start/stop playing the demo.
Sound demo	B7	Start/stop playing the sound demo of the current upper sound.
Beep note	C8	Turn the beep on or off. It is turned on by default. It will produce a beep sound when using keyboard command to change the settings.
Auto power off	A0 + POWER	The instrument will turn off after 30 min when it is not used. To disable this function: when power is turned off, hold A0, then press the POWER switch to turn on the power again.