

**NUX**  
Verdugo Series

**Owner's Manual**  
使用手册



**NDD-6**

#### Copyright

Copyright 2017 Cherub Technology Co. All rights reserved. NUX and Duotime are trademarks of Cherub Technology Co. Other product names modeled in this product are trademarks of their respective companies that do not endorse and are not associated or affiliated with Cherub Technology Co.

#### Accuracy

Whilst every effort has been made to ensure the accuracy and content of this manual, Cherub Technology Co. makes no representations or warranties regarding the contents.

### WARNING!-IMPORTANT SAFETY INSTRUCTIONS BEFORE CONNECTING, READ INSTRUCTIONS

**WARNING:** To reduce the risk of fire or electric shock, do not expose this appliance to rain or moisture.

**CAUTION:** To reduce the risk of fire or electric shock, do not remove screws. No user-serviceable parts inside. Refer servicing to qualified service personnel.

**CAUTION:** This equipment has been tested and found to comply with the limits for a Class B digital device pursuant to Part 15 of FCC Rules. Operation is subject to the following two conditions: (1) This device may not cause harmful interference, and (2) this device must accept any interference received, including interference that may cause undesired operation.



The lightning symbol within a triangle means "electrical caution!" It indicates the presence of information about operating voltage and potential risks of electrical shock.



The exclamation point within a triangle means "caution!" Please read the information next to all caution signs.

1. Use only the supplied power supply or power cord. If you are not sure of the type of power available, consult your dealer or local power company.
2. Do not place near heat sources, such as radiators, heat registers, or appliances which produce heat.
3. Guard against objects or liquids entering the enclosure.
4. Do not attempt to service this product yourself, as opening or removing covers may expose you to dangerous voltage points or other risks. Refer all servicing to qualified service personnel.
5. Refer all servicing to qualified service personnel. Servicing is required when the apparatus has been damaged in any way, such as when the power supply cord or plug is damaged, liquid has been spilled or objects have fallen into the apparatus, the apparatus has been exposed to rain or moisture, does not operate normally or has been dropped.
6. The power supply cord should be unplugged when the unit is to be unused for long periods of time.
7. Protect the power cord from being walked on or pinched particularly at plugs, convenience receptacles and at the point where they exit from the apparatus.
8. Prolonged listening at high volume levels may cause irreparable hearing loss and/or damage. Always be sure to practice "safe listening".

*Follow all instructions and heed all warnings*  
**KEEP THESE INSTRUCTIONS!**

Duotime is a real stereo delay pedal with independent time / sub-division & repeat knobs. In the 80's, all of the professional musicians used rack-mount effects to run stereo delay. It was the golden era of legendary engineering like Lexicon Delta, TC 2290, Eventide H3000, and more. When we talked to “working musicians” we found that they were looking for a great stereo delay with a compact size and ultra-simple controls. So we discussed the absolute essential requirements and developed the duotime Dual Delay Engine. It's ultra-musical, and easy to operate. So, let's dive-in and experience the most versatile delay pedal ever:

*\*All of the brand and model names mentioned on this page are Trademarks of their respective owners, which are in no way associated or affiliated with NUX Effects and Cherub Technology CO. LTD.*

Duotime offers analog delay, tape echo, digital delay, modulation delay, and verb delay.

- Analog Delay (40ms~402ms) is based on the ducket-brigade device (BBD), discrete-time analog delay. The PARAMETER tweaks your modulation depth. When LEVEL and REPEAT are at maximum, turn down the TIME KNOB to zero, and experience the natural infinite feedback of the old school BBD delay.

- Tape Echo (55ms~552ms) is based on RE-201 Tape Echo algorithm with NUX Core Image Technology. Use the PARAMETER to tweak the Saturation, and feel the distorted sound decay. Just like the real tape echo machine, when you adjust LEVEL and REPEAT to maximum, try adjusting the time knob down to zero, and you have infinite feedback and pitch shift flange.

- Digi Delay (80ms~1000ms) is based on the modern digital delay algorithm with magic compression and filter. After reviewing decades of delay algorithm evolution, we noticed musicians were not satisfied with the mathematical digital delay sound. So we

added a bit of non-digital flavour—inspired by Strymon® and Neunaber® making the sound much more musical.

PARAMETER controls the hardness of the repeat signals, so you can feel the unique compressed filter.

- MOD. Delay (20ms~1499ms) is based on the Ibanez DML algorithm; a weird and wonderful modulation delay. It was released in the 80's with experimental nature. We selected the most wonderful aspects highlighting the musical time sync modulation rate offering a simple, seamless romantic tone.

- VERB Delay (80ms~1000ms) is the way to make your delay sound 3 dimensional. Similar to our Atlantic Delay & Reverb, we added Shimmer into the Plate reverb algorithm. It became the iconic sound of our NUX reverb. Inspired by Kit Tang, the famous Hong Kong studio guitarist, Jamtrackcentral® artist, a master of different reverb parallels with different frequency bands to add to his effect yielding an authentic 3 dimensional sound. So we combined parallel digital delay, plate reverb, and various filter shimmers to offer you an unmatched sacred atmosphere to explore.

PARAMETER controls the Plate reverb and shimmer mix.

*\*All the brand and model names mentioned on this page are Trademarks of their respective owners, which are in no way associated or affiliated with NUX Effects and Cherub Technology CO. LTD.*

*\*Using Tap Tempo, the longest delay time can reach 1800ms with all delay styles.*

## Control panel



## Control panel

### LEVEL Knob

When using ENTER LOOP mode, the LEVEL knob will become your LOOP LEVEL to control Phrase Loop volume.

### DELAY TYPE Knob

This is a 5-way rotary switch. You can choose the delay type as ANALOG, TAPE, DIGI, MOD., and VERB.

### PARAMETER Knob

Sets the final compressor Output level. Allows you to balance the signal difference between Input and Output, or you can increase / decrease output level depending upon your essential needs.

	ANALOG	TAPE	DIGI	MOD D	VERB D
PARAMETER	M.DEPTH	SATURATION	HARDNESS	M.DEPTH	VERB LEVEL

For Analog Delay, PARAMETER controls Modulation Depth. Increase to get wider modulated sound.

For Tape Echo, PARAMETER controls signal saturation. Increase to get more saturated and distorted sound.

For Digi Delay, PARAMETER controls signal hardness. Increase to get a more compressed and brighter sound.

For Mod Delay, PARAMETER controls Modulation Depth. Increase to get a wider modulated sound.

For Verb Delay, PARAMETER controls Reverb and Shimmer mix level. Increase to get more depth and a 3 dimensional feeling.

## Control panel

### TIME 1 Knob

Controls delay1's delay time. When in Tap Tempo, it becomes a sub-division according to current parameter.

### REPEAT 1 Knob

Controls delay1's number of repeats.

### TIME 2 Knob

Controls delay2's delay time. When in Tap Tempo, it becomes a sub-division according to current parameter.

### REPEAT 2 Knob

Controls delay2's number of repeats.

### OLED display

Shows current Delay type, and delay time in MS/BPM.

### ON footswitch

Engages the delay effect which becomes: REC/PLAY/DUB when entering PHRASE LOOP mode.

### TAP footswitch

Tap this foot switch to adjust the speed and delay sub-division. You can set the target sub-division by TIME 1 and TIME 2 knobs, then TAP this foot switch to adjust the speed, the DELAY 1 and DELAY 2 will change the delay time according to the current sub-division note signature. Hold this foot switch for 2 seconds, to switch current delay time between MS or BPM.

## Control panel

### LOOP mode

Press ON and TAP foot switch simultaneously, to enter / quit PHRASE LOOP mode. In LOOP mode, press ON foot switch to activate REC/PLAY/DUB and hold to UNDO/REDO as a normal looper pedal. OLED display shows your phrase loop status. LEVEL knob becomes LOOP LEVEL to adjust phrase loop volume. (Pedal will remember the current delay mix level when you enter LOOP mode.) All other knobs work in normal mode independently.

### LOOP FOOTSWITCH

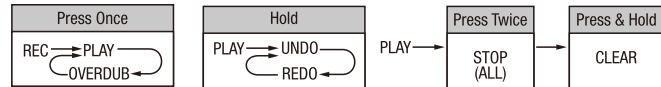

When playing phrase loop, if you quit LOOP mode, the phrase loop will continue playing. Now all KNOBS work in normal mode. OLED display shows delay type and delay time. LEVEL knob reverts back to the role of controlling delay mix level. ( Pedal will remember the current LOOP LEVEL when you quit. )

*\*Duotime offers 40 seconds real stereo phrase loop.*

## I/O Jacks

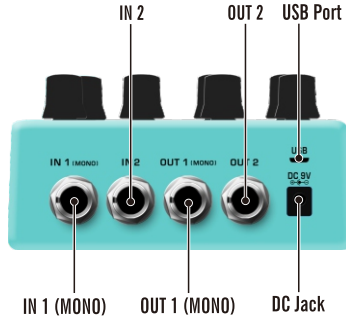

## I/O Jacks

### IN 1 (MONO)

If you only connect with IN 1, then IN 1 signal will run DELAY 1 related to TIME 1 and REPEAT 1 knobs for OUT 1. Pedal will copy IN 1 signal to run DELAY 2 related to TIME 2 and REPEAT 2 knobs for OUT 2.

If you connect using IN 1 and IN 2, then IN 1 and IN 2 will run DELAY 1 for OUT 1 and DELAY 2 for OUT 2 separately.

### IN 2

If you only connect with IN 2, then IN 2 signal will run DELAY 2 related to TIME 2 and REPEAT 2 knobs for OUT 2. Pedal will copy IN 2 signal to run DELAY 1 related to TIME 1 and REPEAT 1 knobs for OUT 1.

If you connect with IN 1 and IN 2, then IN 1 and IN 2 will run DELAY 1 for OUT 1 and DELAY 2 for OUT 2 separately.

### OUT 1 (MONO)

OUT 1 signal is related to DELAY 1.

### OUT 2

OUT 2 signal is related to DELAY 2.

### USB Port

You can update firmware using the USB port. Please check our product page “Support” and follow instructions.

### DC Jack

Use ONLY: 9V Negative Tip power with 300ma ⊕⊖.

## Connect Applications

### 1. Stereo Out, Either Mono In or Stereo In

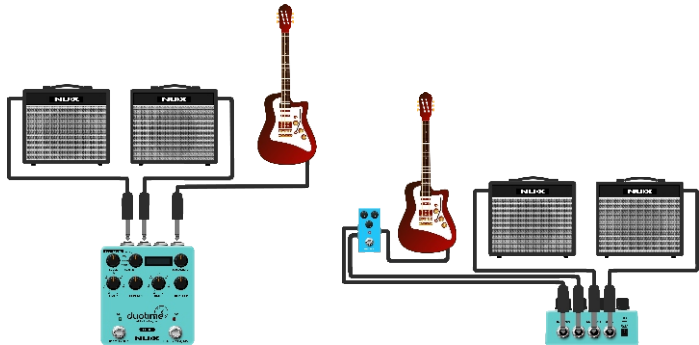
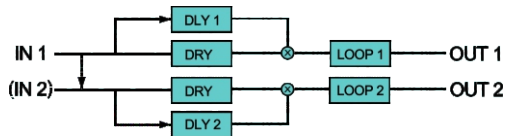

## Connect Applications

### 2. Mono Out: Dly 1 or Dly 2

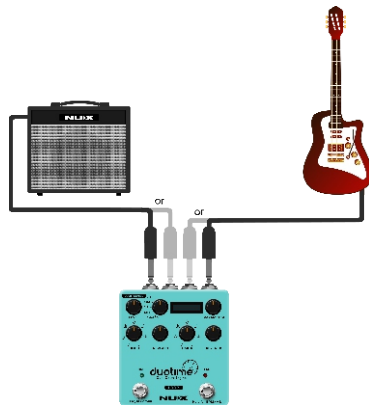
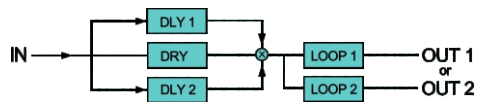

## Connect Applications

### 3. Dly 1 serial Dly 2 by a cable

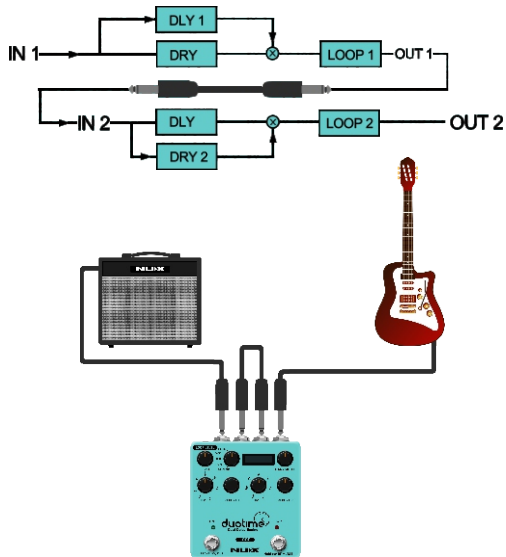

## Technical Specifications

- Sampling rate: 48kHz
- A/D Converter: 32Bit
- Signal Processing: 32Bit
- Frequency Response: 20Hz~20kHz -  $\pm 1$ dB
- Maximum input level: 10dBu/2.8Vrms
- Input Impedance: 5M $\Omega$
- System Latency: 1ms
- Maximum output level: 10dBu/2.8Vrms
- Output Impedance: 1k $\Omega$
- Dynamic Range: 102dBu
- THD+N Ratio: 0.02%/-70dB(A-Weighting)@input 1Vrms, 1kHz
- Power: 9V DC(Negative tip,Optional ACD-006A adapter)
- Current Draw: less than 150mA
- Dimensions: 105(L)X115(W)X58(H)mm
- Weight: 440g

Accessories: User manual

\*Specifications and features are subject to change without notice.

### CE mark for European Harmonized Standards

CE Mark which is attached to our company's products of Battery mains the product is in fully conformity with the harmonized standard(s) EN 61000-6-3:2007+A1:2011 & EN 61000-6-1:2007 Under the Council Directive 2004/108/EC on Electromagnetic Compatibility.



www.nuxefx.com

Made in China



**请注意！重要安全说明。**  
在连接使用前，阅读以下说明。

**警告：**为减少火灾或触电的危险，请勿将本产品置于雨中或潮湿的地方。

**注意：**为避免火灾或触电等危险，请勿擅自拆卸本产品。维修本产品内部部件对于非专业人员来说较为困难，若有损坏请交给专业维修人员处理。

**注意：**本产品已经过测试，证明符合FCC规则第15部分的B级数字设备的限制规定。操作应符合以下两个条件：（1）本产品不会产生有害干扰，且（2）本产品必须接受任何干扰，包括可能会导致非正常操作的干扰。

1. 仅能使用与出厂附带规格相同的电源及电源线。如果您不确定可用的电源类型，请咨询您的经销商或当地的电力公司。
2. 请勿放置在热源附近，如散热器、电热器，或其它产生高热量的设备。
3. 请勿让液体、灰尘及其它物体进入本产品。
4. 打开或取下后盖板可能会产生触电或其它危险，请勿尝试自行维修本产品。如需维修，请联系我司售后热线，或交给专业的维修人员。
5. 当设备遭遇电源线或插头损坏、不明物体进入、进水等情况时，请谨慎使用并主动联系售后维修。
6. 如果长时间不使用本产品，应拔掉电源线。
7. 避免踩踏电源线，避免过度绷紧电源线。
8. 人耳长时间接收高音音量声音可能会导致无法挽回的听力损害，请始终保持“安全聆听”。

请遵守所有的指示和注意所有警告并保留这些说明！

Duotime是一款带独立Time/Sub-division及Repeat调节的真立体声延迟效果器。80年代所有专业乐手都使用机架效果器来获得立体声延迟效果，那是一个属于Lexicon Delta、TC2290、Eventide H3000等传奇产品的黄金年代。在与当代职业乐手们的交流过程中，我们发现他们一直在寻找一款音色出众、操作简单、小巧便携的立体声延迟效果器，NUX Duotime Dual Delay Engine便应运而生了。

Duotime内置了五种延迟模式：模拟延迟（ANALOG），磁带延迟（TAPE）、数字延迟（DIGI）、调制延迟（MOD）以及混响延迟（VERB）。

#### ●模拟延迟（40毫秒~402毫米）

基于BBD的斗链式模拟延迟效果。PARAMETER旋钮控制调制深度。当LEVEL及REPEAT旋钮置于最大位置同时将TIME旋钮归零时，您便可以体验到经典BBD自然延迟的无限反馈。

#### ●磁带延迟（55毫秒~552毫秒）

基于NUX Core Image技术的Roland RE-201 Tape Echo延迟效果。使用PARAMETER旋钮来调整饱和度，感受失真音色的衰减。当LEVEL及REPEAT旋钮置于最大位置同时将TIME旋钮归零时，您便可以获得如同原型机一般的无限反馈及由音高变化的镶边音色。

#### ●数字延迟（80毫秒~1000毫秒）

巧妙融合了压缩及滤波算法的现代数字延迟效果。在回顾了数十年的延迟

## 控制面板

效果算法发展历程后，我们发现乐手们对于过于公式化的数字延迟并不满意，所以受Strymon®和Neunaber®的启发，我们给Duotime的延迟注入了非“数字”化元素，使得其延迟效果更具音乐性。

PARAMETER旋钮控制重复（延迟）信号的强度，转动此旋钮来感受其独特的压缩和滤波。

### •调制延迟（20毫秒~1499毫秒）

基于发布于80年代的Ibanez DML——一款怪异而奇妙的调制延迟效果器开发。我们取其精华并凸显了调制速率与延迟时间同步，从而提供一种简单无缝且浪漫的音色。

### •混响延迟（80毫秒~1000毫秒）

让音色三维化的一种混响延迟。类似于亚特兰提克，我们在平板混响算法中加入了Shimmer效果，这也成为NUX混响的标志性特征。受香港著名录音室吉他演奏家Kit Tang (Jamtrackcentral®艺术家) 的启发，他熟练使用具有不同频段的不同混响并行技术，以产生真实的3D声音。所以我们结合了并行数字延迟和板混响。



## 控制面板

### LEVEL旋钮

调节延迟效果干湿比。

LOOP模式下，调节循环乐句音量。

### 延迟模式选择旋钮

转动此旋钮来选择任意一种延迟模式。

### PARAMETER旋钮

	ANALOG	TAPE	DIGI	MOD D	VERB D
PARAMETER	M.DEPTH	SATURATION	HARDNESS	M.DEPTH	VERB LEVEL

不同模式下该旋钮的功能不一致。

模拟延迟模式下，PARAMETER旋钮控制调制深度。

磁带延迟模式下，PARAMETER旋钮控制信号饱和度。调大可以获得更饱和和失真的音色。

数字延迟模式下，PARAMETER旋钮控制信号硬度，调大可以获得更为明亮的音色。

调制延迟模式下，PARAMETER旋钮控制调制的深度，调大可以获得更宽的调制音色。

混响延迟模式下，PARAMETER旋钮控制混响和Shimmer效果的混合比，调大可以使音色更深邃和更具立体感。

### TIME 1旋钮

控制DELAY1的延迟时间。当打点设速激活时，此旋钮可以根据当前参数选择细分时值。

## 控制面板

### REPEAT 1旋钮

控制DELAY1的重复次数。

### TIME 2旋钮

控制DELAY2的延迟时间。当打点设速激活时，此旋钮可以根据当前参数选择细分时值。

### REPEAT 2旋钮

控制DELAY2的重复次数。

### On踩钉

开启关闭本体，当LOOP模式激活时此踩钉可以控制录音/播放/叠加录音。

### TAP踩钉

拍点该踩钉来决定延迟速度及延迟的对应拍点音符。你可以通过TIME1和TIME2旋钮设置预期的音符，然后拍点该踩钉来定速，此时延迟1跟延迟2会根据当前设置的音符来改变对应速度。长按住该踩钉两秒钟可将显示屏的延迟时长单位显示切换为MS或BPM。

### OLED显示屏

显示当前延迟类型和延迟时间（MS/BPM）。

## 控制面板

### LOOP模式

同时踩下ON踩钉和TAP踩钉以激活或关闭LOOP模式。LOOP模式下可使用ON踩钉来进行录音/播放/叠加录音操作，踩住ON踩钉可以进行撤销/恢复最近一次录音。OLED显示屏会显示LOOP状态，LEVEL旋钮可以用于调整循环乐句回放的音量大小（机器会自动保存进入LOOP模式前的延迟混合比）。其余旋钮的功能与普通模式下保持一致。

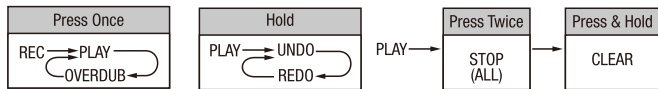

在循环乐句播放的时候，如果您选择退出LOOP模式，循环乐句会继续播放，所有旋钮恢复正常工作模式的功能，OLED显示屏会显示延迟类型与延迟时间。LEVEL旋钮恢复控制延迟混合比功能（机器会自动保存当前LOOP回放的音量大小设置）。

\*Duotime的loop core 最长可提供40s的录音时间。

## 输入与输出接口



## 输入与输出接口

---

### IN 1输入接口 (单声道)

如果输入 (单声道) 信号仅接入IN1, 从IN1接口的输入信号 (DELAY1) 会经由TIME1旋钮及REPEAT1旋钮的控制由OUT1接口输出, 同时机器会复制从IN1输入的信号 (DELAY2), 经由TIME2旋钮及REPEAT2旋钮的控制由OUT2输出信号。

如果输入 (立体声) 信号同时接入IN1与IN2, 那么IN1与IN2会分别受控然后分别经由OUT1及OUT2 输出。

### IN 2 输入接口

如果输入 (单声道) 信号仅接入IN2, 从IN2接口的输入信号 (DELAY1) 会经由TIME2旋钮及REPEAT2旋钮的控制由OUT2接口输出, 同时机器会复制从IN2输入的信号 (DELAY1), 经由TIME1旋钮及REPEAT1旋钮的控制由OUT1输出信号。

如果输入 (立体声) 信号同时接入IN1与IN2, IN1与IN2会分别受控, 然后分别经由OUT1及OUT2 输出。

### OUT 1输出接口 (单声道)

OUT1输出DEALY1的信号。

### OUT 2输出接口

OUT2输出DEALY2的信号。

## 输入与输出接口

---

### USB接口

Micro-USB接口, 可连接电脑升级机器的固件。请至NUX中文官方网站获取最新固件及更新方法。

### 电源接口

请使用品质可靠的内负外正9V效果器专用电源。推荐使用NUX ACD-006A。

## 连接方法

### 1. 立体声输出

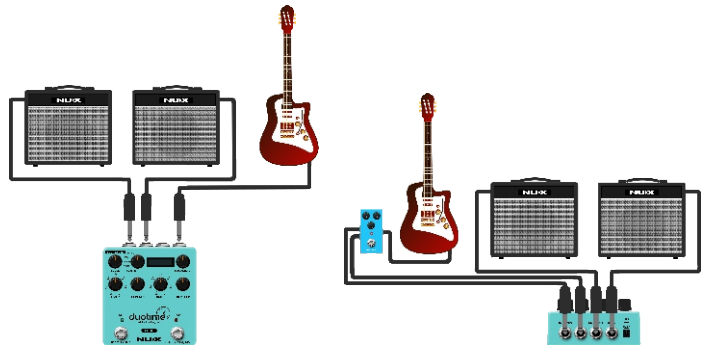
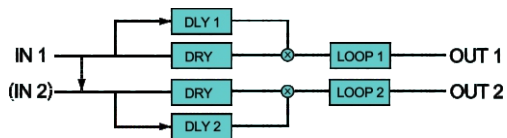

## 连接方法

### 2. 单声道输出

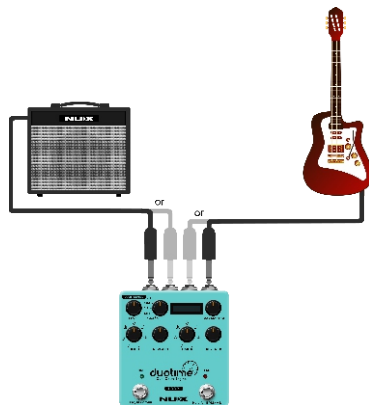
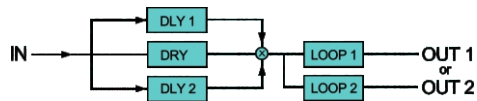

## 连接方法

### 3. 串联输出

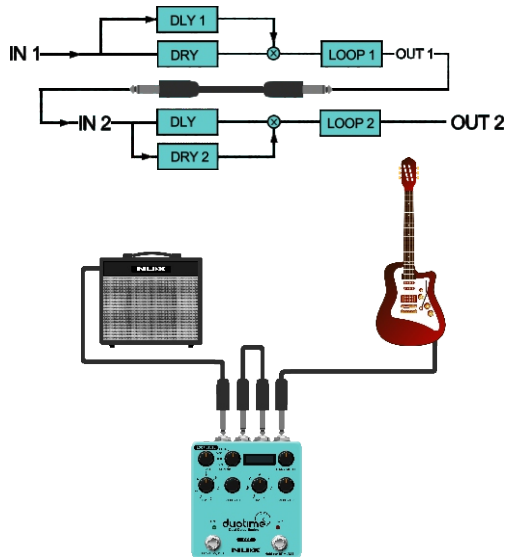

## 技术规格

- 采样率: 48kHz
- 数模转换: 32Bit
- 信号处理精度: 32Bit
- 频率响应范围: 20Hz~20kHz±1dB
- 最大输入电平: 10dBu/2.8Vrms
- 输入阻抗: 5MΩ
- 系统延迟: 1毫秒
- 最大输出电平: 10dBu/2.8Vrms
- 输出阻抗: 1kΩ
- 动态范围: 102dBu
- 总谐波失真加噪声比: 0.02%/-70dB(A-Weighting)@input 1Vrms, 1kHz
- 电源: 9V直流 (内负外正, 推荐选用ACD-006A)
- 需求电流: 150毫安
- 产品尺寸: 105(长)X115(宽)X58(高)毫米
- 产品重量: 440克

随机附件: 使用说明书, 产品合格证。

\*技术规格如有变更, 恕不另行通知。

## 有关产品中所含有害物质的说明

本资料就本公司产品中所含的特定有害物质及其安全性予以说明。

本资料适用于2007年3月1日以后本公司所制造的产品。

### 环保使用期限



此标志适用于在中国国内销售的电子信息产品，表示环保使用期限的年数。所谓环保使用期限是指在制造日起的规定的期限内，产品中所含的有害物质不致引起环境污染不会对人身、财产造成严重的不良影响。环保使用期限仅在遵照产品使用说明，正确使用产品的条件下才有效。不当的使用，将会导致有害物质泄漏的危险。

### 产品中有毒有害物质或元素的名称及含量

部件名称	有害有毒物质或元素					
	铅(Pb)	汞(Hg)	镉(Cd)	六价铬(Cr(VI))	多溴联苯(PBB)	多溴二苯醚(PBDE)
外壳(壳体)	×	●	●	●	●	●
电子部件(印刷电路板等)	×	●	×	●	●	●
附件(电源线、交流适配器等)	×	●	●	●	●	●

●：表示该有害有毒物质在该部件所有均质材料中的含量均在SJ/T11363-2006 标准规范的限量要求以下。  
×：表示该有害有毒物质至少在该部件的某一均质材料中的含量超出SJ/T11363-2006 标准规定的限量要求。  
因根据现有的技术水平，还没有什么物质能够代替它。

## 质量承诺

亲爱的**NUX**用户，在您使用本产品时，请仔细阅读产品说明书，当您有疑问和困难时，请拨打售后服务热线：**400-990-9866**

- 一周内出现质量问题可退货退款
- 一年内出现质量问题可免费维修
- 一月内出现质量问题可调换
- 终身享有咨询和维修服务

\* 请向销售商索取有效购买凭证并予以保存。

## 换修政策

### 一、包换政策：

- 消费者自购机之日起1个月之内，在正常使用情况下，出现非人为的产品性能故障，且产品外观及包装保持完好的可向所购机的经销商换机。
- 消费者在换机时应出示由经销商开出的购机收据及保修卡，否则经销商可以不予更换。

### 二、保修政策：

产品在购买之日起1年内，可免费享有维修服务；对于超过1年的产品及人为或不可抗力因素造成损坏的产品，我司可提供有偿维修服务。

### 售后服务地址

广东省珠海市高新区唐家湾镇科技九路10号  
珠海市蔚科科技发展有限公司 售后服务部  
邮编：519085

制造商：深圳市蔚科电子科技有限公司 制造商地址：深圳市南山区蛇口兴华路6号南海意库1号楼507 电话：0755-2686 9866 网址：www.nuxefx.com 生产商：珠海市蔚科科技发展有限公司 生产商地址：珠海市高新区唐家湾镇科技九路10号 电话：0756-3689866 执行标准：Q/WK DZ 001-2020