

Thunder-KS I

Compact, multi-tasking subwoofers

USER GUIDE



V1.rev.3

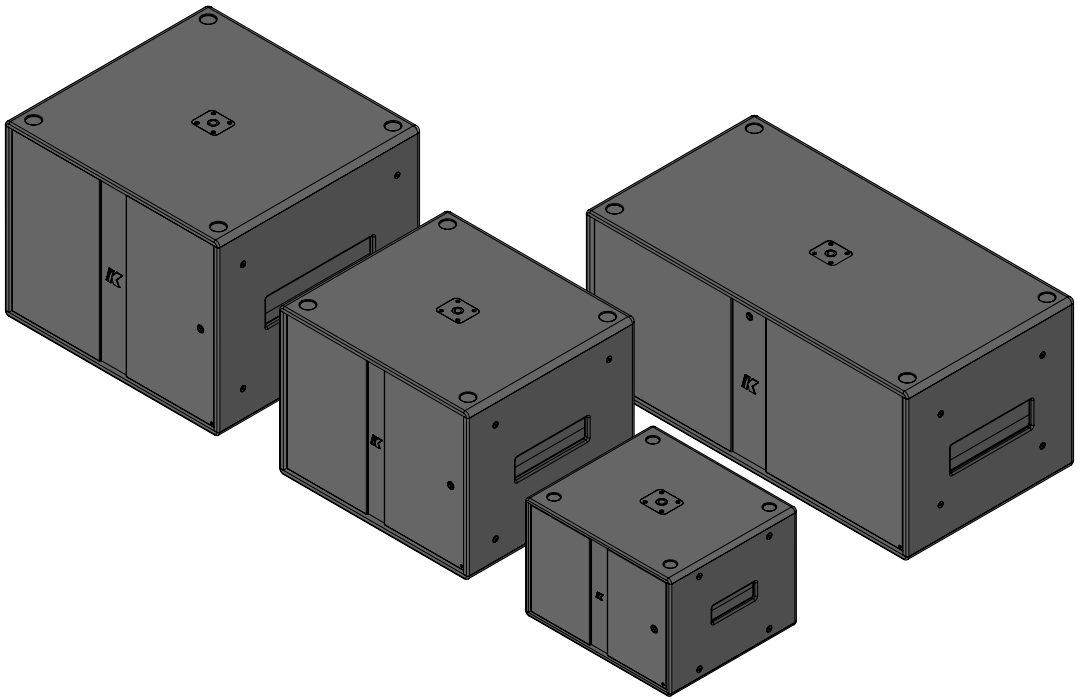

K-ARRAY
Unique Audio Solutions

V1.rev.3

IMPORTANT SAFETY INSTRUCTIONS



CAUTION

RISK OF ELECTRIC SHOCK
DO NOT OPEN



ATTENTION: RISQUE DE CHOC ELECTRIQUE NE PAS OUVRIR

CAUTION: TO REDUCE THE RISK OF ELECTRIC SHOCK,
DO NOT REMOVE COVER (OR BACK).
NO USER-SERVICEABLE PARTS INSIDE.
REFER SERVICING TO QUALIFIED SERVICE PERSONNEL.



This symbol alerts the user to the presence of recommendations about the product's use and maintenance.



The lightning flash with arrowhead symbol within an equilateral triangle is intended to alert the user to the presence of uninsulated, dangerous voltage within the product enclosure that may be of magnitude to constitute a risk of electrical shock.

The exclamation point within an equilateral triangle is intended to alert the user to the presence of important operating and maintenance (servicing) instructions in this guide.



Operator's manual; operating instructions
This symbol identifies the operator's manual that relates to the operating instructions and indicates that the operating instructions should be considered when operating the device or control close to where the symbol is placed.



For indoor use only
This electrical equipment is designed primarily for indoor use.



WEEE
Please dispose of this product at the end of its operational lifetime by bringing it to your local collection point or recycling center for such equipment.



This device complies with Restriction of Hazardous Substances Directive.

WARNING



Failure to follow these safety instructions could result in fire, shock or other injury or damage to the device or other property.

General heed and warnings

- Read these instructions.
- Keep these instructions.
- Heed all warnings.
- Follow all instructions.
- Do not use this apparatus near water.
- Clean only with dry cloth.
- Do not block any ventilation openings. Install in accordance with the manufacturer's instructions.
- Do not install near any heat sources such as radiators, heat registers, stoves, or other apparatus (including amplifiers) that produce heat
- Do not defeat the safety purpose of the polarized or grounding plug. A polarized plug has two blades with one wider than the other. A grounding plug has two blades and a third grounding prong. The wide blade or the third prong is provided for your safety. If the provided plug does not fit into your outlet, consult an electrician for replacement of the obsolete outlet.
- Only use attachments/accessories specified by the manufacturer.
- Protect the power cord from being walked on or pinched particularly at the plugs, convenience receptacles, and at the point where they exit from the apparatus.
- Clean the product only with a soft and dry fabric. Never use liquid cleaning products, as this may damage the products cosmetic surfaces.
- Use only with the cart, stand, tripod, bracket, or table specified by the manufacturer, or sold with the apparatus. When a cart is used, use caution when moving the cart/apparatus combination to avoid injury from tip-over.
- Unplug this apparatus during lightning storms or when unused for long periods of time.
- Avoid placing the product in a location under direct sunlight or near any appliance that generates UV (Ultra Violet) light, as this may change the product surface finishing and cause a change in color.
- Refer all servicing to qualified service personnel. Servicing is required when the apparatus has been damaged in any way, such as power-supply cord or plug is damaged, liquid has been spilled or objects have fallen into the apparatus, the apparatus has been exposed to rain or moisture, does not operate normally, or has been dropped.
- CAUTION: These servicing instructions are for use by qualified service personnel only. To reduce the risk of electric shock, do not perform any servicing other than that contained in the operating instructions unless you are qualified to do so.
- WARNING: Only use attachments/accessories specified or provided by the manufacturer (such as the exclusive supply adapter, battery, etc.).
- Before turning the power on or off for all devices, set all volume levels to minimum.



This apparatus is intended for professional use.

Installation and commissioning may only be carried out by qualified and authorized personnel.

Thunder-KS I

USER GUIDE

V1.rev.3

- Use only speaker cables for connecting speakers to the speaker terminals. Be sure to observe the amplifier's rated load impedance particularly when connecting speakers in parallel. Connecting an impedance load outside the amplifier's rated range can damage the apparatus.
- K-array cannot be held responsible for damage caused by improper use of the loudspeakers.
- K-array will not shoulder any responsibilities for products modified without prior authorization.

FCC Statement

This equipment has been tested and found to comply with the limits for a Class B digital device, pursuant to part 15 of the FCC Rules. These limits are designed to provide reasonable protection against harmful interference in a residential installation. This equipment generates, uses and can radiate radio frequency energy and, if not installed and used in accordance with the instructions, may cause harmful interference to radio communications. However, there is no guarantee that interference will not occur in a particular installation. If this equipment does cause harmful interference to radio or television reception, which can be determined by turning the equipment off and on, the user is encouraged to try to correct the interference by one or more of the following measures:



1. Reorient or relocate the receiving antenna.
2. Increase the separation between the equipment and receiver.
3. Connect the equipment into an outlet on a circuit different from that to which the receiver is connected.
4. Consult the dealer or an experienced radio/TV technician for help.

FCC Radiation Exposure Statement

This device complies with FCC radiation exposure limits set forth for an uncontrolled environment. This equipment must be installed and operated in accordance with provided instructions and the antenna(s) used for this transmitter must be installed to provide a separation distance of at least 20 cm from all persons.

This device complies with Part 15 of the FCC Rules. Operation is subject to the following two conditions:

1. this device may not cause harmful interference, and
2. this device must accept any interference received, including interference that may cause undesired operation.

CAUTION! Any changes or modifications not expressly approved by the party responsible for compliance could void the user's authority to operate the equipment.

Canadian Statement

This device complies with Industry Canada's licence-exempt RSSs. Operation is subject to the following two conditions: this device may not cause interference, and this device must accept any interference, including interference that may cause undesired operation of the device.

The device meets the exemption from the routine evaluation limits in section 2.5 of RSS 102 and compliance with RSS-102 RF exposure, users can obtain Canadian information on RF exposure and compliance.

This equipment should be installed and operated with a minimum distance of 20 centimeters between the radiator and your body.

CE Statement

K-array declares that this device is in compliance with applicable CE standards and regulations. Before putting the device into operation, please observe the respective country-specific regulations!



Trademark Notice

All trademarks are the property of their respective owners.

Thunder-KS I

USER GUIDE

V1.rev.3

This page intentionally left blank

Thunder-KS I

USER GUIDE

V1.rev.3

Index

Unpacking

- Self powered subwoofer rear panel
- Passive subwoofer rear panel

Getting Started

- Active Subwoofer
(KS1I, KS2I, KS3I, KS4I)
- Passive Subwoofer
(KS1PI, KS2PI, KS3PI, KS4PI)

Introduction

Connectivity

- K-array Connect App
- K-framework3
- Connectivity Reset

Active Subwoofer Rear Panel

Passive Subwoofer Rear Panel

AC Mains Supply

Wirings

- Input wiring
 - Thunder-KS Analog Input
 - Thunder-KS Digital Input
- Thunder-KSP Speaker Input
- SpeakON Cable Default Wiring
 - One-channel wiring
 - Two-channel wiring
- Output wiring
 - Example Configurations

K-array Connect Mobile App

- Connection and Discovery
 - Scan QR Code and Connect
 - Manually Connect

Device Web App

- Media Player
- Output Configuration
- INPUT PATCH and MATRIX
- System Update
 - Online System Update
 - System update via USB

DSP Block Diagram

Accessories

Service

Cleaning

Mechanical drawings

- Thunder-KS1I/KS1PI
- Thunder-KS2I/KS2PI
- Thunder-KS3I/KS4PI
- Thunder-KS4I/KS4PI

Technical Specifications

V1.rev.3

Thank you for choosing this K-array product!

To ensure proper operation, please carefully read the owner's manuals and safety instruction before using the products.

After reading this manual, be sure to keep it for future reference.

Should you have any questions about your new device please contact K-array customer service at support@k-array.com or contact the official K-array distributor in your country.

K-array Thunder-KS subwoofers gives you all the boom with bass you need for installation and live applications. With both passive and active models in various sizes starting from 12" to 21" and dual 18", the Thunder-KS subwoofers are high performance sub-bass systems featuring a woofer with magnet structure and suspension engineered for maximum linear excursion.

The pocket handles facilitate the pick-up and positioning, while rigging is made easy by means of the M8 threaded holes at the sides designed for accepting either eye-bolts or the K-EXTFRAMES accessories available for the Thunder-KS3I and Thunder-KS4I subwoofers. The M20 thread mount position at the top side allows to attach top speakers making the Thunder-KS subwoofers convenient to use in portable full-range systems, ideal for applications in theaters, concert halls, parties and restaurant installations.

More than just powered subwoofers, K-array Thunder-KS subwoofers active models depart from traditional subs in that their "smart" design puts electronics as the central component, transforming the mid-low frequency loudspeaker into a proper tool for the management and processing of the audio signal.

Thunder-KS I

USER GUIDE

V1.rev.3

Unpacking

Each K-array loudspeaker is built to the highest standard and thoroughly inspected before leaving the factory.

Upon arrival, carefully inspect the shipping carton, then examine and test your new amplifier. If you find any damage, immediately notify the shipping company. Check that the following parts are supplied with the product.

- 1x Subwoofer unit: model and version shall be one from the following list:
 - Thunder-KS1 I
 - Thunder-KS1P I
 - Thunder-KS2 I
 - Thunder-KS1P I
 - Thunder-KS3 I
 - Thunder-KS3P I
 - Thunder-KS4 I
 - Thunder-KS4P I
- 1x The quick guide
- 1x Power cord in self powered models packages only (i.e. KS1 I, KS2 I, KS3 I, KS4 I).

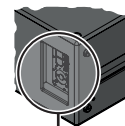
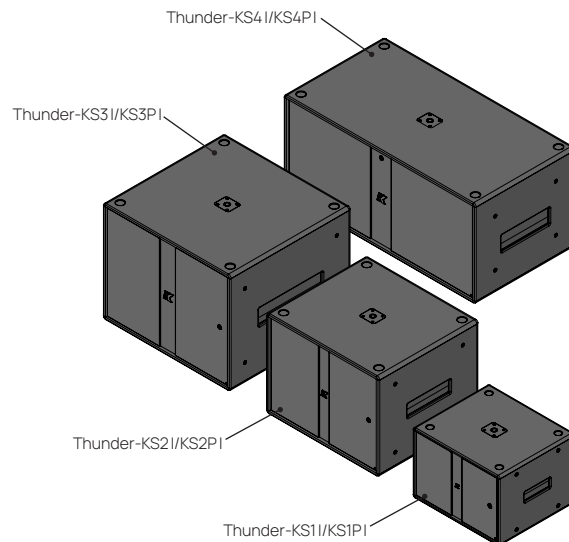

Self powered subwoofer rear panel

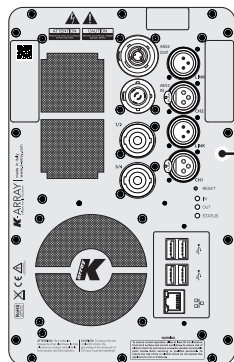

Package content:
1x Active subwoofer
1x Power cord

Passive subwoofer rear panel

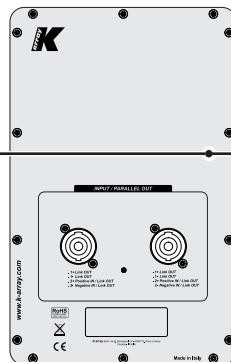

Package content:
1x Passive subwoofer

V1.rev.3

Getting Started

According to the version and model, follow these steps to make the system operating:

Active Subwoofer (KS1I, KS2I, KS3I, KS4I)

1. Connect the input and output signal cables according to the configuration you want to achieve.
2. Connect the power cord to an AC mains socket outlet and to the powerCon TRUE connector on the Thunder-KS rear panel: the Thunder-KS switches on when the powerCon TRUE connector is locked and electricity flows.
3. Hold your mobile device (smartphone or tablet): ensure the Wi-Fi connectivity is on;
4. You can either connect to the Thunder-KS DSP manually or by scanning the rear QR code.
 - Automatic connect: launch the K-array Connect app and scan the rear QR code to connect.
 - Manually connect:
 - a. Force refresh the list of available Wi-Fi networks available on your device: the Thunder-KS built-in Wi-Fi hotspot has an SSID starting with K-array followed by the subwoofer's serial number, for example: K-array-K140AP0107
 - b. Connect to the Thunder-KS Wi-Fi SSID: the default password is the subwoofer's serial number, for example K140AP0107 (to be written all caps).
 - c. Launch the K-array Connect app
5. In the K-array Connect app Devices menu, select the Thunder-KS active subwoofer you want to connect to or open the browser (Google Chrome recommended) and go to the default IP address of the DSP web app: 192.168.0.1.
6. Use the app for managing your subwoofer.

Passive Subwoofer (KS1PI, KS2PI, KS3PI, KS4PI)

- A. Use a four wire speakOn cable with NL4 speakOn connectors. Check the SpeakOn terminal configuration: by default the Thunder-KSP subwoofers are set to receive signals on the +2-2 SpeakON terminals.
- B. Connect the speaker cable to the SpeakON connector on the Thunder-KSP rear panel.
- C. Connect the other side of the speaker cable to a power amplifier or to a Thunder-KSP active subwoofer.
- D. On the active driving unit load the proper device preset according to the Thunder-KSP passive subwoofer model.

K-array Connect Devices menu

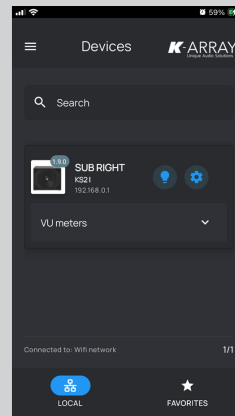

Web App (on the web browser)

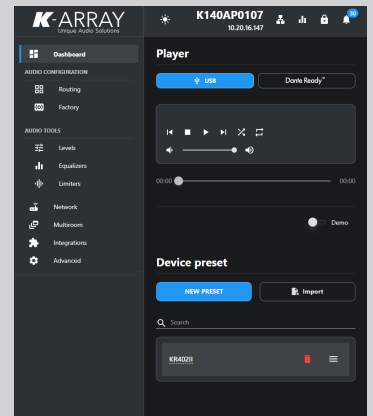

Thunder-KS I

USER GUIDE

V1.rev.3

Introduction

The Thunder-KS subwoofers are available in two versions: self powered (active) and passive loudspeakers. The former implement 4-channel power amplifier module with built-in DSP, the latter shall be driven by either an external K-array power amplifier or by another Thunder-KS active subwoofer.

Active sub	woofer	Amp module	Power Rating
Thunder-KS1I	12"	4-ch class-D	1500W @ 4Ω
Thunder-KS2I	18"	4-ch class-D	1500W @ 4Ω
Thunder-KS3I	21"	4-ch class-D	2500W @ 4Ω
Thunder-KS4I	2x18"	4-ch class-D	2500W @ 4Ω

Passive sub	woofer	Impedance	Power Handling
Thunder-KS1PI	12"	8 Ω	1200W
Thunder-KS2PI	18"	8 Ω	1400W
Thunder-KS3PI	21"	4 Ω	2800W
Thunder-KS4PI	2x18"	4 Ω	2800W

The active subwoofers implement multichannel amplifier modules with DSP that features four power output channels available to drive further passive loudspeakers.

The K-array Connect app and the K-framework3 software provide access to the DSP features for managing the output section and signal routing, making any Thunder-KS active subwoofer a flexible driving unit.

In order to remote control any Thunder-KS active unit download the K-array Connect app or the K-framework3 software:



Connectivity

The Thunder-KS active subwoofers can be controlled remotely by a mobile device or desktop PC/MAC.

K-array Connect App

K-array Connect is the mobile app for managing and controlling any Thunder-KS active subwoofer with a mobile device (smartphone or tablet) over a wireless connection to the Thunder-KS built-in Wi-Fi hotspot.

Download the K-array Connect mobile APP from the dedicated store of your mobile device. Refer to paragraph [Device Web App](#) for details about the system configuration with the K-array Connect App.

K-framework3

K-framework3 is the software dedicated to professionals and operators looking for a powerful tool for designing and managing a large number of units in demanding applications. The K-framework3 features acoustical simulation, device discovery and DSP managing for setup and tuning sound reinforcement systems.

Download the K-framework3 software from the [K-array website](#).

Connectivity Reset

In order to reset the built-in Wi-Fi hotspot parameters and wired connectivity follows next steps:

1. Switch on the active subwoofer;
2. Keep pressed the RESET button for 10 to 15 seconds.

While keeping pressed the RESET button the status LED lights on purple.

After almost 15 seconds the Wi-Fi hotspot switches on and reverts to the default SSID (K-array- < serial number >). IP addressing of both the wired and wireless connections is set to DHCP.

V1.rev.3

Active Subwoofer Rear Panel

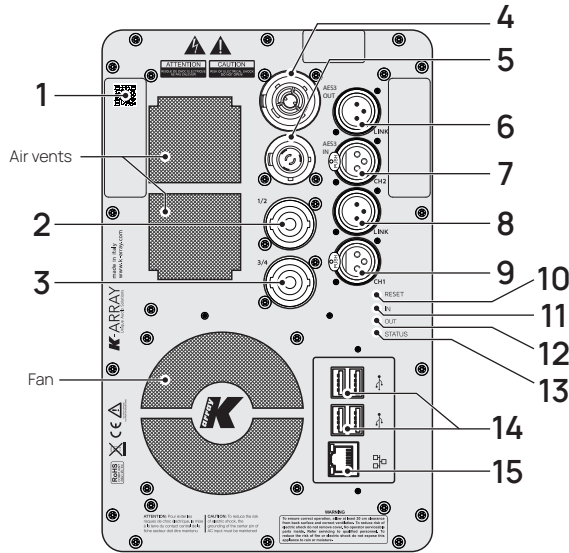

1. QR Code for the K-array Connect app remote connection
2. SpeakON NL4 speaker output channels 1 & 2*
3. SpeakON NL4 speaker output channels 3 & 4
4. PowerCon TRUE link (AC mains out)
5. PowerCon TRUE inlet (AC mains in)
6. XLR-M channel 2 balanced line output or channels 3 & 4 AES3 output (user selectable via software)
7. XLR-F channel 2 balanced line input or channels 3 & 4 AES3 input (user selectable via software)
8. XLR-M channel 1 balanced line output
9. XLR-F channel 1 balanced line input
10. Reset button
11. Input signal LED monitor
12. Output signal LED monitor
13. System status LED
14. USB ports
15. RJ45 Ethernet port

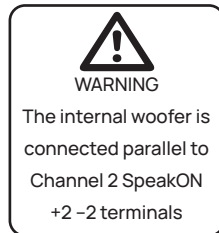

Passive Subwoofer Rear Panel

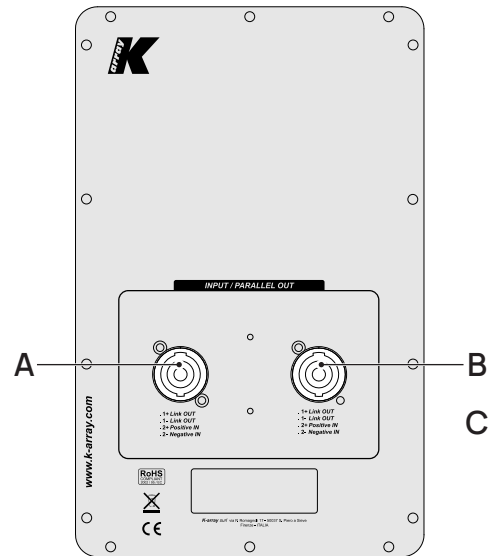

- A. SpeakON NL4
 - 2+ 2- Subwoofer signal / 1+ 1- trough
- B. SpeakON NL4
 - 2+ 2- Subwoofer signal / 1+ 1- trough

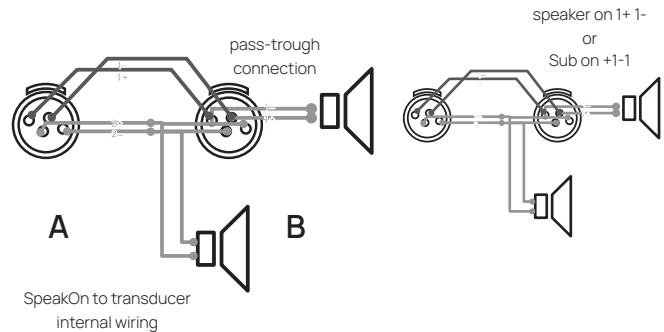

SpeakOn to transducer
internal wiring

Thunder-KS I

USER GUIDE

V1.rev.3

AC Mains Supply

K-array Thunder-KS active subwoofers shall be properly connected to an AC power distribution system.

The Thunder-KS active subwoofers implement an autorange power amplifier suiting AC operating voltage in the range 100-240 V_{AC}, 50-60 Hz.



Make sure the operating voltage is steadily between 100 V and 230 V AC



To operate safely and effectively, it is extremely important that the entire system is properly grounded.



Refer to professionals for selecting the proper wire gauge according to local regulations.



Use provided power cord with powerCon TRUE connector for powering the Thunder-KS active subwoofers.

Insert the powerCon TRUE flying connector into the inlet and then rotate it clockwise. Once properly plugged and powered, the system status LED lights on.

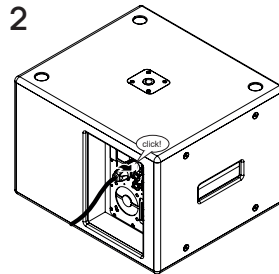
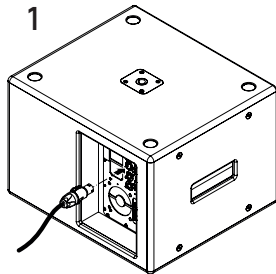

Wirings

Input wiring

K-array Thunder-KS active subwoofers accept both analog and digital inputs.

K-array Thunder-KSP passive subwoofers accept shall be driven by an external power audio amplifier, namely either a K-array Kommander-KA amplifier or a Thunder-KS active subwoofer.

Thunder-KS Analog Input

Use the XLR-F input connectors labeled CH1 and CH2 to send line level input signals to the internal amplifier and DSP.

By default:

- signal input on XLR CH1 is used to drive the subwoofer and the speaker outputs 1&2.
- signal input on XLR CH2 is used to drive the speaker outputs 3&4.

Custom signal routing can be made via software by means of the internal DSP matrix.

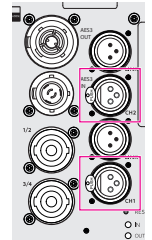

The input signals can be fed balanced or unbalanced.

XLR PIN	Signal Polarity
1	GND
2	HOT (+)
3	COLD (-)

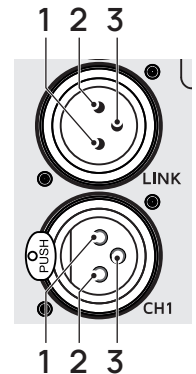
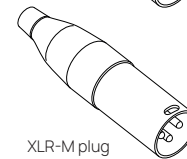
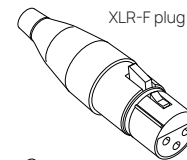

V1.rev.3

Thunder-KS Digital Input

The Thunder-KS I active subwoofers accept AES3 digital signals (2-channel stream) and optionally a Dante® stream (up to two input channels).

AES3 Input

In order to feed the subwoofer with an AES3 digital signal, the XLR CH2 input connector shall be toggled to AES3 via software (K-array Connect or K-framework3).

The AES3 digital input signals are routed internally to the input channels 3 and 4 and mirrored to the AES3 OUT XLR connector.

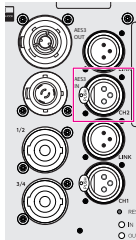

Dante Input

The Thunder-KS I are DanteReady™ devices. By default Dante is not active: end-users may purchase and add two Dante input channels to the Thunder-KS I after initial purchase.

The Audinate Dante Controller (version 4.5.0 or later) includes the Dante Ready Activator that manages the purchase and activation.

After purchase and activation, the Dante license is transferred to the Thunder-KS I active subwoofer and retained by its DSP.

The Dante stream can be fed to the Thunder-KS I via the RJ45 Ethernet Port on the back panel.

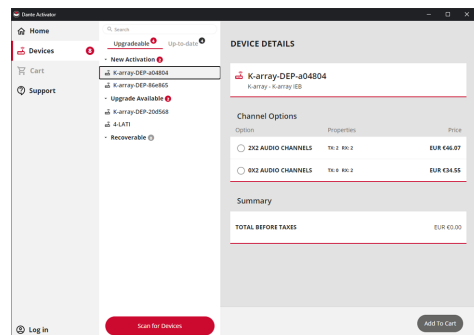
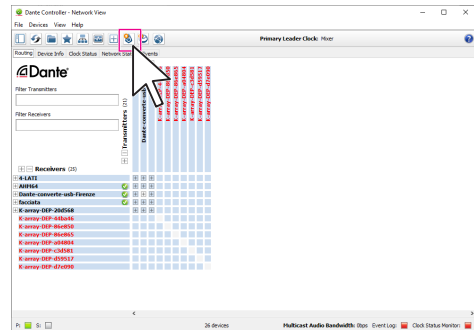
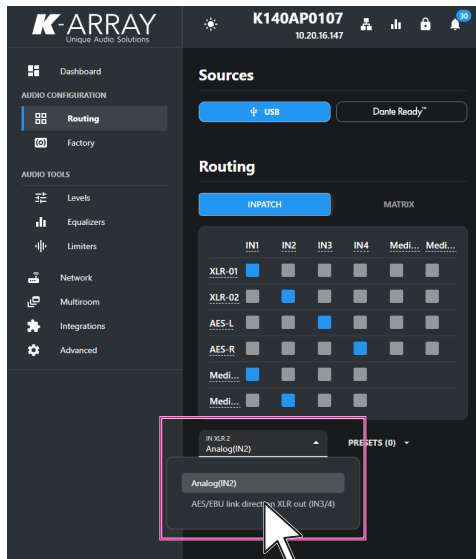
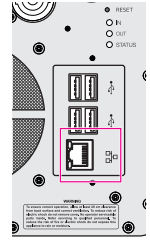

Thunder-KS I

USER GUIDE

V1.rev.3

Thunder-KSP Speaker Input

The NL4 speakON connectors on the K-array Thunder-KSP passive subwoofers back panel may accept analog signals on either +1 -1 terminals, or +2 -2 terminals.



By default the Thunder-KSP passive subwoofers transducer(s) are connected to the NL4 speakON +2 -2 terminals: signal polarity is +2 HOT, -2 COLD.



Any other Mid/High speaker can be connected to the NL4 speakON +1 -1 terminals (pass trough/ LINK): signal polarity is +1 HOT, -1 COLD.



Other KS (same model) speaker can be connected to the NL4 speakON +2 -2 terminals (pass trough/ LINK): signal polarity is +1 HOT, -1 COLD.

SpeakON Cable Default Wiring

One-channel wiring

Hi/Mid- and full-range loudspeakers are usually wired on +1 -1.

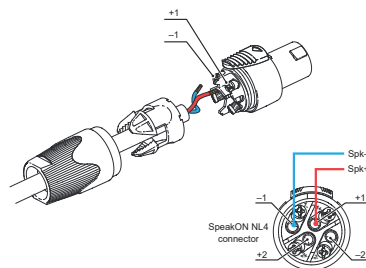

Subwoofers are usually wired on +2 -2.

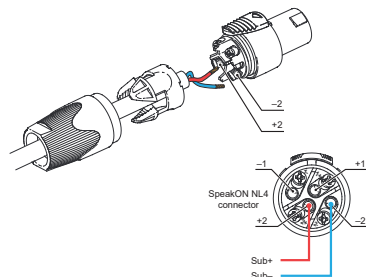

Two-channel wiring

Internal subwoofer on 2+ / 2-; 1+ / 1- pass-through for external low-sub or Hi/Mid-range.

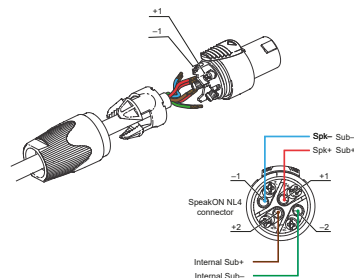

Output wiring

K-array Thunder-KS active subwoofers feature 4-channel amplifier module whose output channel 2 is connected to the built-in transducer(s).

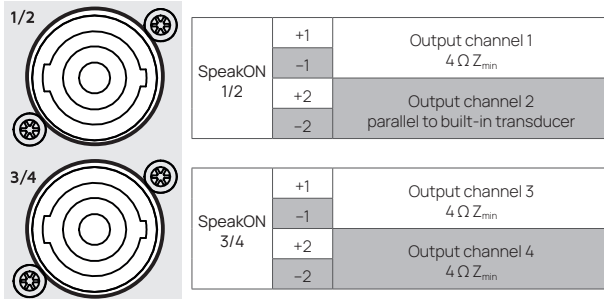

The subwoofer factory preset is applied to the output channel 2 on speakON 1/2 terminals +2 -2.



WARNING: Thunder-KS3I and Thunder-KS4I
Avoid connecting any load on output channel 2 on speakON 1/2 terminals +2 -2.

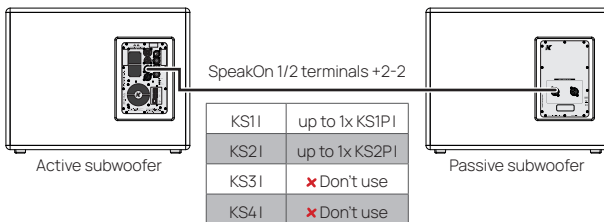

Example Configurations

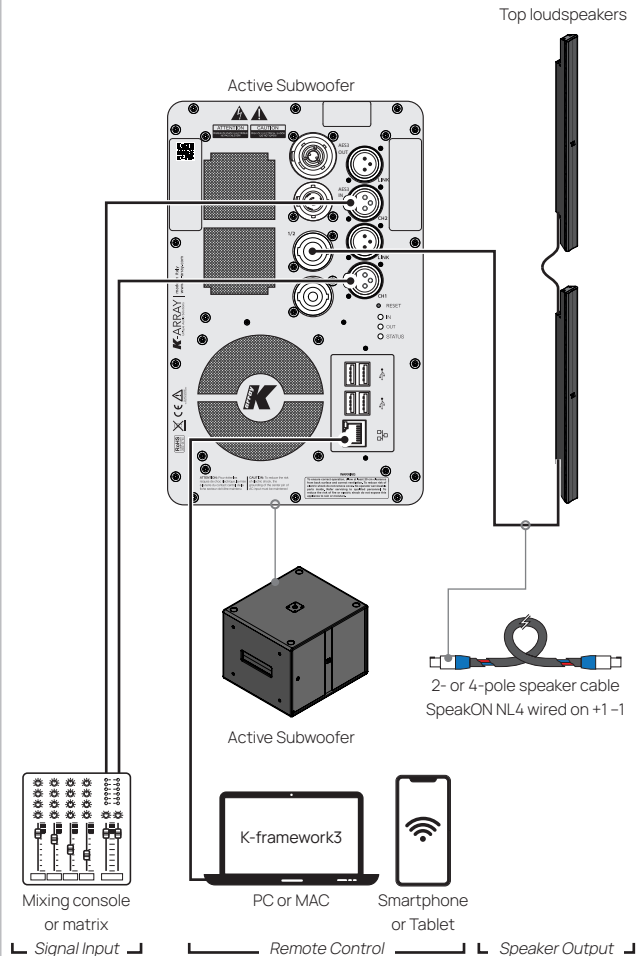

Thunder-KS I

USER GUIDE

V1.rev.3

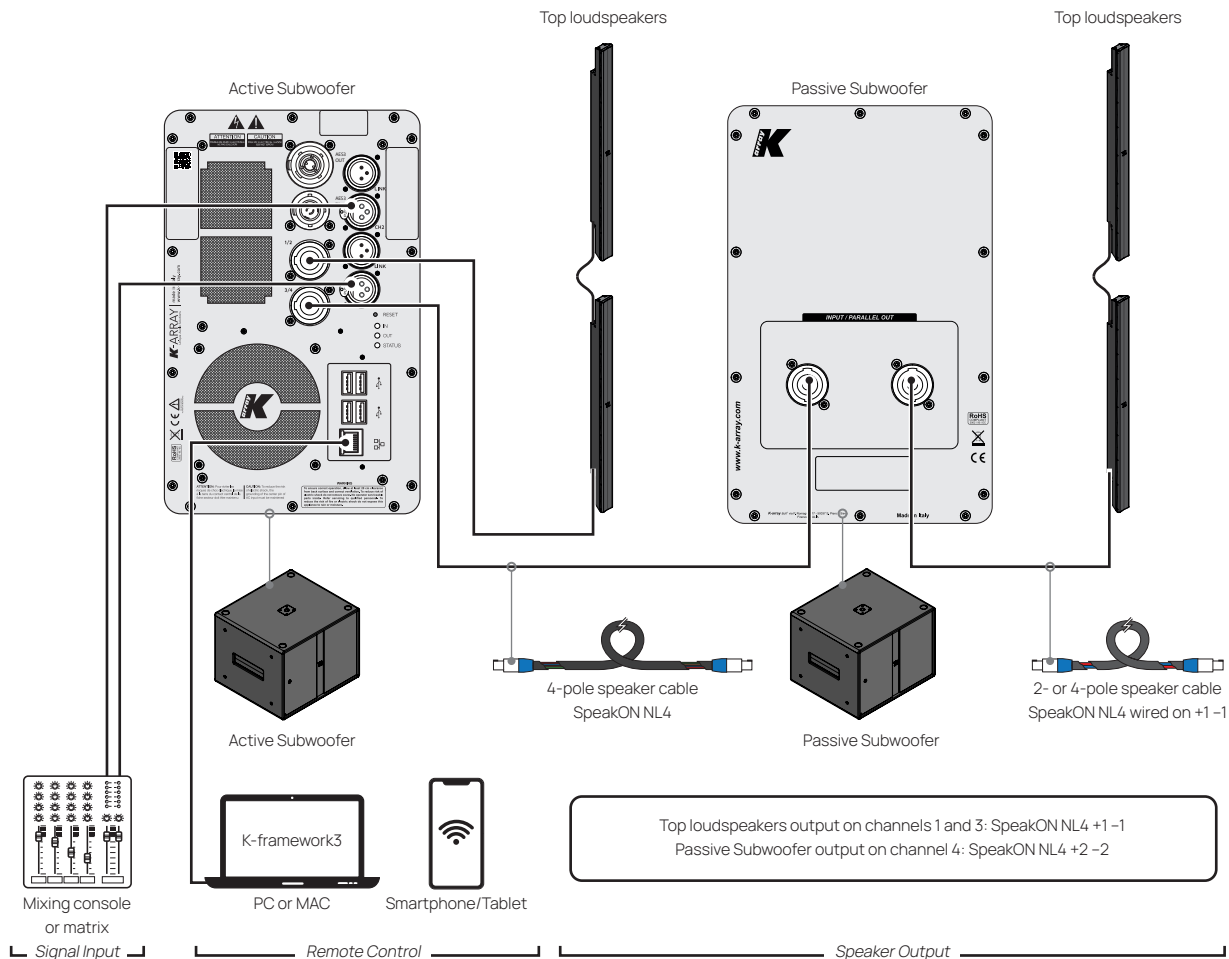

V1.rev.3

K-array Connect Mobile App

The K-array Connect mobile app is designed to allow any Android and iOS mobile device (smartphone or tablet) to connect and manage any Thunder-KS active subwoofer wireless.



Connection and Discovery

The K-array Connect mobile app is designed to connect to the Thunder-KS active subwoofers built-in Wi-Fi hotspot. Connection can be established either manually or by scanning the QR Code printed on the active subwoofer rear panel.

Scan QR Code and Connect

1. Click on Scan QR code, or open the main menu (top left icon) and select QR code.

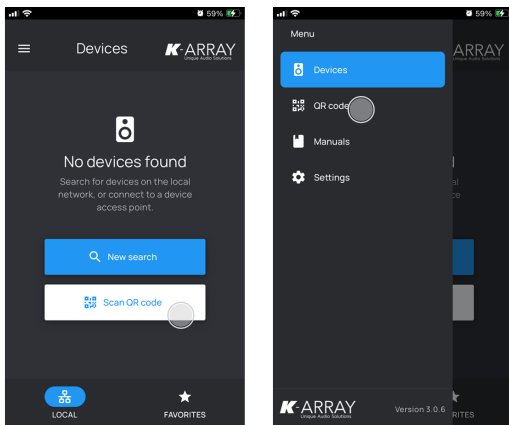

2. Use the mobile device built-in camera to spot the QR Code on the Thunder-KS active subwoofer rear panel.

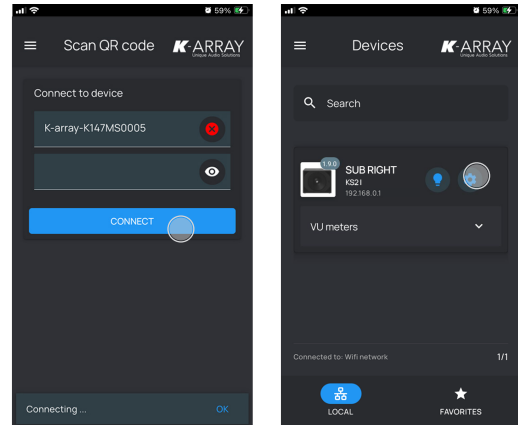

3. Let your device connect to the subwoofer's Wi-Fi hotspot.
4. In few seconds the K-array Connect mobile app will show the Thunder-KS subwoofer in the device list.

Manually Connect

- A. Go to the Wi-Fi connection settings of your mobile device.
- B. Among the available Wi-Fi, select the one whose SSID starts with K-array followed by the device serial number (e.g. K-array-K140AP0107).
- C. You will be asked to insert the Wi-Fi password: the default Wi-Fi password of any K-array device's built-in hotspot is the device serial number, case sensitive (e.g. K140AP0107). You can find the device serial number in the back panel label and in the Wi-Fi SSID.
- D. Once connected, open the web browser in your mobile device (Google Chrome recommended) and insert the device default Wi-Fi IP: 192.168.0.1.

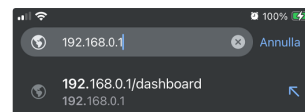

Thunder-KS I

USER GUIDE

V1.rev.3

Device Web App

Once connected to the Thunder-KS built-in Wi-Fi hotspot, the active subwoofer can be remotely managed via its Web App.

The Web App is stored into the device and is the user interface of the K-array osKar operating system and DSP.

Use the web browser on your mobile device to access the Web App on the device default Wi-Fi IP address 192.168.0.1.

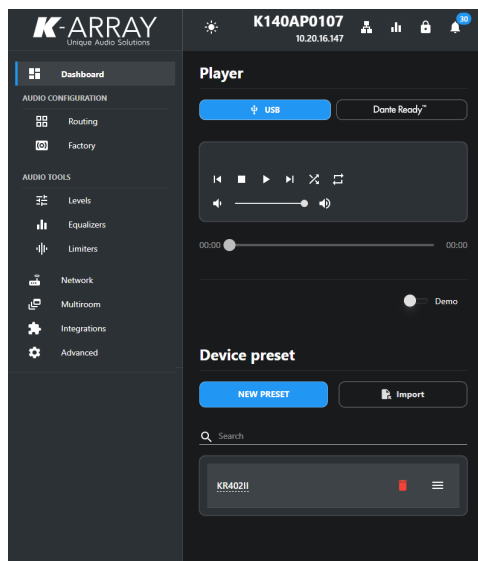

The Web App can be opened on every web browser (Google Chrome recommended) either over a wireless connection on mobile device and a wired connection on personal computer. In order to access the device Web App type the device IP address on the web browser address bar.

The Web App menu gives access to the device settings: the dashboard collects the main features and comprises a media player that can stream audio from either a usb device, a remote cloud storage or Dante.

Media Player

The Thunder-KS active subwoofer built-in DSP implements a media player that can be used to playback audio from digital sound sources.

By default the media player lists the audio files saved on any USB drive connected on the rear panel USB ports and routes the sound to the DSP input channels IN1 and IN2.

The media player's output channels are shown in the INPUT PATCH, providing to route the digital signals from the media player to any DSP input channels.

When Dante is active, in order to route the Dante stream to the output channels, the media player shall be used and set to Dante Ready.

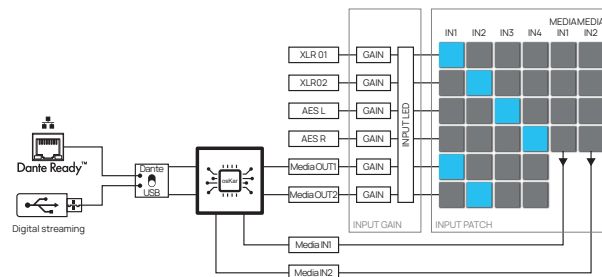

The media player's MEDIA INs can receive the signals from the input connectors (XLR1, XLR2, AES3), providing to route these signals to DANTE.

Output Configuration

Under the Factory menu, the Output Configuration allows to configure the Thunder-KS' amplifier output channels with the proper loudspeaker factory preset.

In order to drive the built-in transducer, the default Thunder-KS loudspeaker factory preset is loaded on the output channel 2.

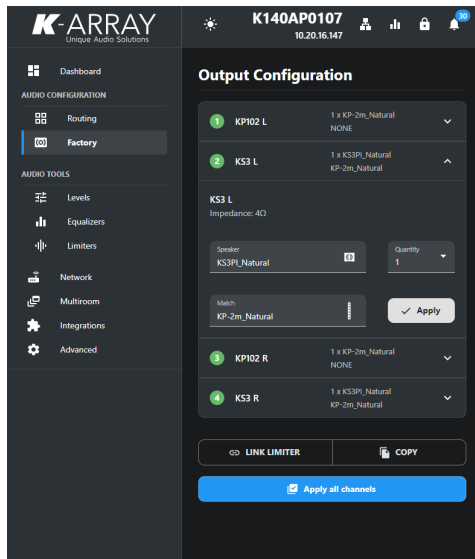

The amplifier module output channels shall be properly configured to drive other passive loudspeakers: the loudspeaker factory presets are available for K-array and KGEAR products.

The subwoofer crossover frequency depends on the loudspeaker type and model connected to the Thunder-KS speaker output channel: select the proper loudspeaker factory preset in the *match* field in output channel 2.

INPUT PATCH and MATRIX

The Routing menu provides access to the INPUT PATCH and the MATRIX.

The INPUT PATCH provides to route the physical connections to the DSP input channels. The DSP manages the signal before the amplifier output stage.

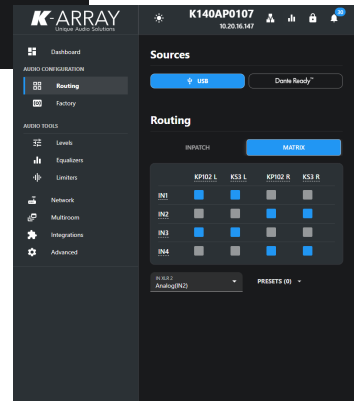
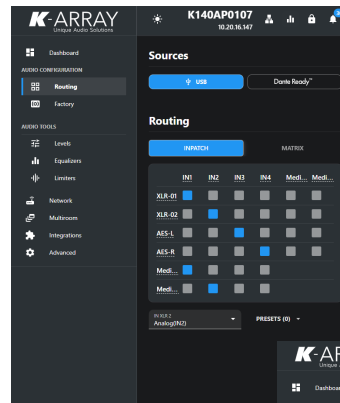

The Matrix provides to route the DSP outputs to the amplifier module physical speaker output connectors.

Thunder-KS I

USER GUIDE

V1.rev.3

System Update

The Advanced menu provides access to advanced settings: among others, System Updates allows to check over the Internet for updates and provides procedures for updating the system on line or via USB.

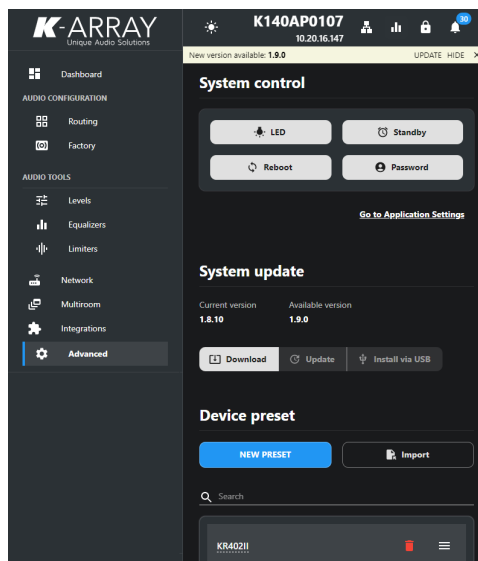

Online System Update

If the Thunder-KS active subwoofer is connected to the Internet the system automatically looks for updates and suggest you to update the system with a banner on top of the main window.

1. Click on the Download button to start downloading the updated software. Once the download ends up, the Update button lights on.
2. Click on the Update button to start updating the Thunder-KS active subwoofer software. The updating process lasts in about 15 minutes. After updating the Thunder-KS active subwoofer reboots.

System update via USB

- A. Prepare a USB drive with the system update files.
Download the system update file form the K-array website at <https://software.k-array.com/oskar>



- B. In the root of a USB drive make a folder named **update** (case sensitive).
- C. Copy the **.mender** update file in the **update** folder.
- D. Plug the USB drive to a free USB port on the Thunder-KS rear panel.
- E. If not already operating, switch on the Thunder-KS active subwoofer and access its Web app.
- F. Press on the Install via USB button to start updating the Thunder-KS active subwoofer.

The update procedure lasts in about 15 minutes. After updating the Thunder-KS active subwoofer reboots.

V1.rev.3

DSP Block Diagram

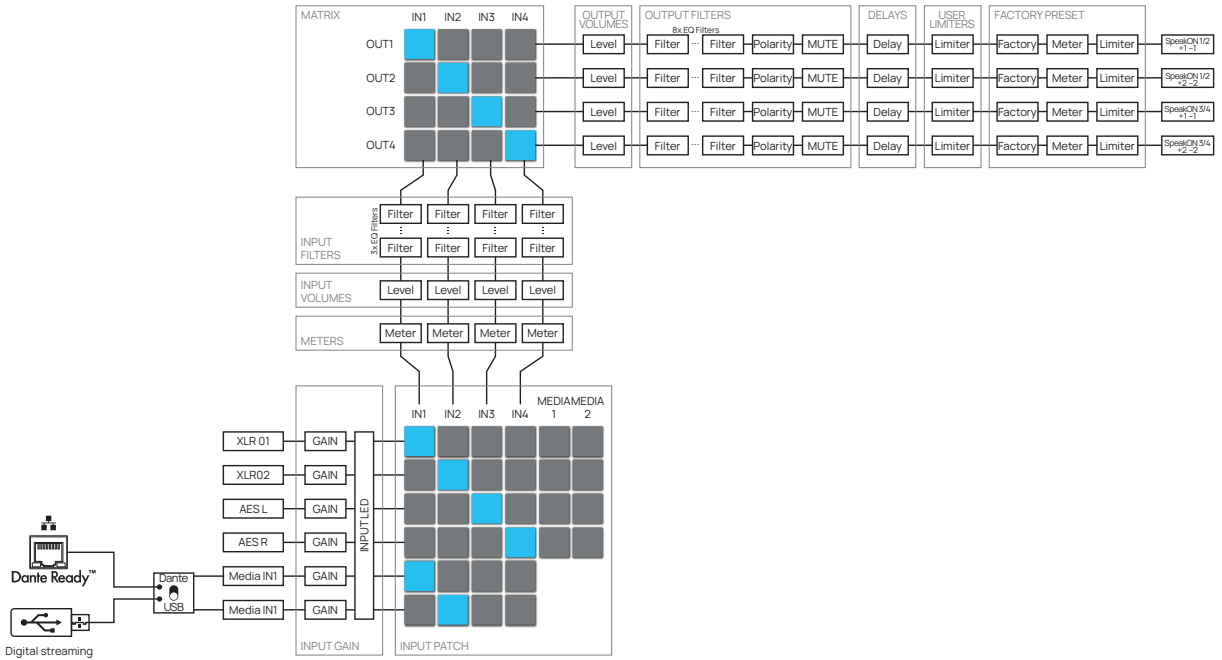

Thunder-KS I

USER GUIDE

V1.rev.3

Accessories

All units	
K-FOOT3	Adapter for standing loudspeakers on top of Thunder sub
Thunder-KS3I / KS3PI	
K-EXTFRAME3	Hardware to suspend KS3I (kit for 1 unit)
K-HCFLY2I	Fly bar for KH2I-KS3I
K-HCDOLLY2I	Dolly for KH2I-KS3I
Thunder-KS4 / KS4PI	
K-EXTFRAME4	Hardware to suspend KS4I (kit for 1 unit)
K-HCFLY35I	Fly bar for KH5I-KH3I-KS4I
K-HCDOLLY35I	Dolly for KH3I-KH5I-KS4I

The K-EXTFRAME3 and K-EXTFRAME4 accessory hardwares allow to suspend the Thunder-KS subwoofers in loudspeaker clusters.

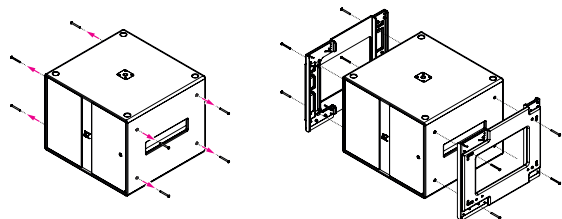

The Thunder-KS subwoofers can be suspended as stand alone units. Screw eight M8 eye bolts (four per side) to the unit and hang them to the rigging points.

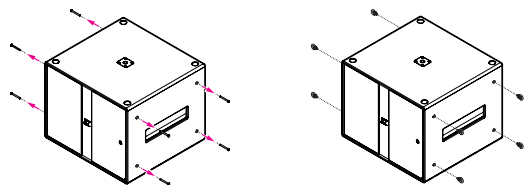

Service

To obtain service:

1. Please have the serial number(s) of the unit(s) available for reference.
2. Contact the official K-array distributor in your country: find the Distributors and Dealers list on [K-array website](#). Please describe the problem clearly and completely to the Customer Service.
3. You will be contacted back for on-line servicing.
4. If the problem cannot be resolved over the phone, you may be required to send the unit in for service. In this instance, you will be provided with an RMA (Return Material Authorization) number which should be included on all shipping documents and correspondence regarding the repair. Shipping charges are the responsibility of the purchaser.

Any attempt to modify or replace components of the device will invalidate your warranty. Service must be performed by an authorized K-array service center.

Cleaning

Use only a soft, dry cloth to clean the housing. Do not use any solvents, chemicals, or cleaning solutions containing alcohol, ammonia, or abrasives. Do not use any sprays near the product or allow liquids to spill into any openings.

V1.rev.3

Mechanical drawings

Thunder-KS1 I/KS1PI

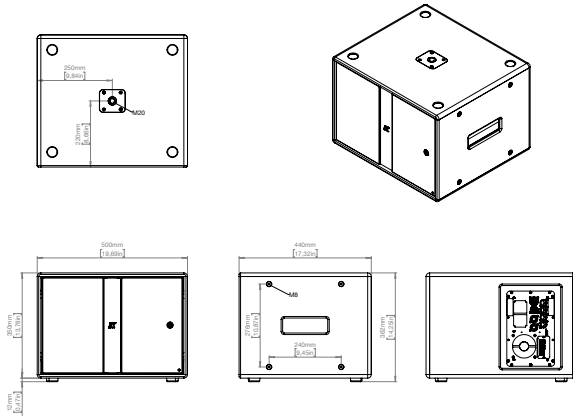

Thunder-KS3 I/KS4PI

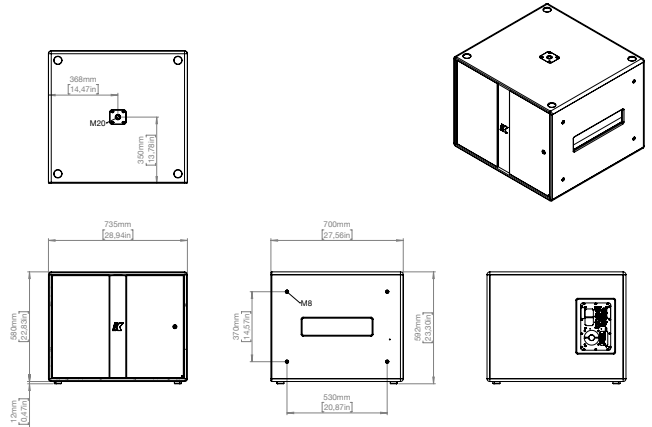

Thunder-KS2 I/KS2PI

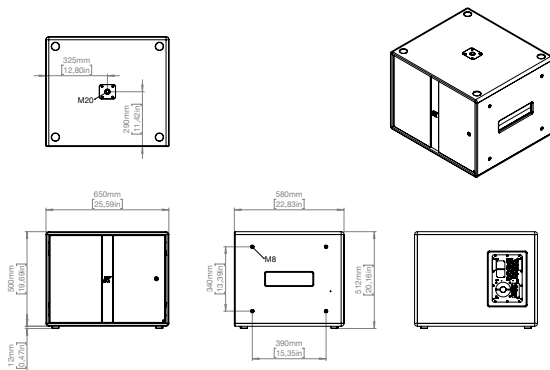

Thunder-KS4 I/KS4PI

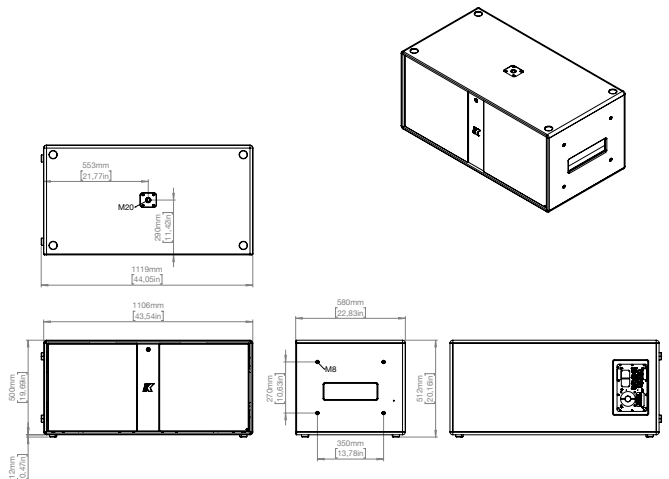

Thunder-KS I

USER GUIDE

V1.rev.3

Technical Specifications

	Thunder-KS1I	Thunder-KS2I	Thunder-KS3I	Thunder-KS4I
Type	Active subwoofer			
Transducers	12" neodymium magnet woofer	18" neodymium magnet woofer	21" neodymium magnet woofer	2x 18" neodymium magnet woofer
Frequency Response ¹	35 Hz – 150/450 Hz (-6 dB) crossover dependent	35 Hz – 150/450 Hz (-6 dB) crossover dependent	30 Hz – 150/450 Hz (-6 dB) crossover dependent	35 Hz – 150/450 Hz (-6 dB) crossover dependent
Crossover	DSP-controlled, Low Pass @ 150 Hz up to 450 Hz, preset dependent			
Max SPL ²	134 dB peak	137 dB peak	139 dB peak	141 dB peak
Coverage	Omni			
Connectors	Line Input 2x XLR-F analog balanced / AES3 input Mains powerCON TRUE1 TOP; 16 A true mains Networking and Data 1x RJ45 4x USB-A		Line Output 2x XLR-M Link analog balanced / AES3 output Speaker Output 2x SpeakON NL4(Ch1 1+/-1 - Ch2 2+/-2)	
DSP	Input gain, routing matrix, delay, full parametric IIR filters (Peaking, Shelving, Hi/Lo pass, Hi/Lo Butterworth), On-board preset, Remote monitoring			
Remote control	Wi-Fi mobile app or K-framework3 software via wired Ethernet connection			
Amplifier module	4-channel switching mode, Class D			
Output power ³	4x1500 W @ 4 Ω	4x1500 W @ 4 Ω	4x2500 W @ 4 Ω	4x2500 W @ 4 Ω
MAINS Operating Range	100-240V AC, 50-60 Hz with PFC			
Power Consumption	600 W @ 8 Ω load, Pink noise, 1/4 rated power	600 W @ 8 Ω load, Pink noise, 1/4 rated power	600 W @ 8 Ω load, Pink noise, 1/8 rated power	600 W @ 8 Ω load, Pink noise, 1/8 rated power
Protections	Over Temp. (Power Limiting – Thermal Shutdown), Short Circuit/Overload Output Protection, Power Limiting, Clip Limiter/Permanent Signal Limiter, High Frequency Protection			
IP Rating	IP53			
Dimensions (WxHxD)	500 x 350 x 440 mm (19.7 x 13.8 x 17.3 in)	650 x 500 x 580 mm (25.6 x 19.7 x 22.8 in)	735 x 580 x 700 mm (28.9 x 22.83 x 20.87 in)	1106 x 500 x 580 mm (43.5 x 19.7 x 22.8 in)
Weight	21,6 kg (47.62 lb)	37,6 kg (82.9 lb)	56 kg (123.4 lb)	60 kg (132.3 lb)

¹ Extensible with dedicated preset according to the midrange crossover point.

² Maximum SPL is calculated using a signal with crest factor 4 (12dB) measured at 1 m.

³ CTA-2006 (CEA-2006) Amplifier Power Standards, single channel driven.

Thunder-KS I

USER GUIDE

V1.rev.3

	Thunder-KS1PI	Thunder-KS2PI	Thunder-KS3PI	Thunder-KS4PI
Type	Passive subwoofer			
Transducers	12" neodymium magnet woofer	18" neodymium magnet woofer	21" neodymium magnet woofer	2x 18" neodymium magnet woofer
Frequency Response ¹	35 Hz – 150/450 Hz (-6 dB) crossover dependent	35 Hz – 150/450 Hz (-6 dB) crossover dependent	30 Hz – 150/450 Hz (-6 dB) crossover dependent	35 Hz – 150/450 Hz (-6 dB) crossover dependent
Crossover	External DSP-controlled, Low Pass @ 150 Hz up to 450 Hz, preset dependent			
Max SPL ²	134 dB peak	137 dB peak	139 dB peak	141 dB peak
Nominal Impedance	8 Ω	8 Ω	4 Ω	4 Ω
Power Handling	1200 W _{peak}	1400 W _{peak}	2800 W _{peak}	2800 W _{peak}
Coverage	Omni			
Connectors	Speaker input/parallel output 2x SpeakON NL4 (2+ 2- signal / 1+ 1- link)			
IP Rating	IP54			
Dimensions (WxHxD)	500 x 350 x 440 mm (19.7 x 13.8 x 17.3 in)	650 x 500 x 580 mm (25.6 x 19.7 x 22.8 in)	735 x 580 x 700 mm (28.9 x 22.83 x 20.87 in)	1106 x 500 x 580 mm (43.5 x 19.7 x 22.8 in)
Weight	18 kg (39.7 lb)	34 kg (75 lb)	49.2 kg (108.5 lb)	53.2 kg (117.3 lb)

¹ Extensible with dedicated preset according to the midrange crossover point.

² Maximum SPL is calculated using a signal with crest factor 4 (12dB) measured at 1 m.



K-ARRAY Srl
Via P. Romagnoli 17 - 50038
Scarperia e San
Piero
Firenze - Italy
P.IVA/VAT/CF
06206990480
Phone: +39 055- 8487222
Email: info@karray.com