

DIGITAL PIANO

Owner's Manual

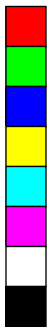
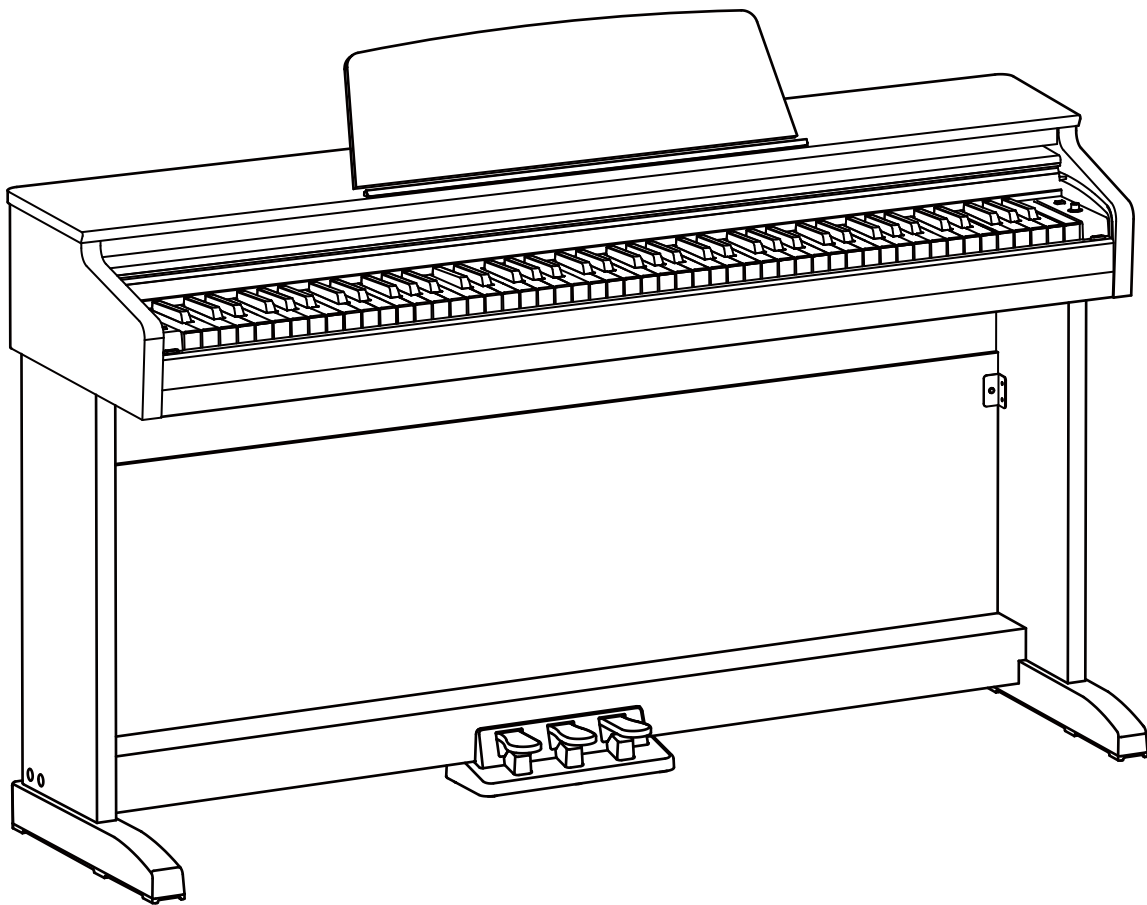

INFORMATION FOR YOUR SAFETY!

THE FCC REGULATION WARNING (for USA)

This equipment has been tested and found to comply with the limits for a Class B digital device, pursuant to Part 15 of the FCC Rules.

These limits are designed to provide reasonable protection against harmful interference in a residential installation. This equipment generates, uses, and can radiate radio frequency energy and, if not installed and used in accordance with the instructions, may cause harmful interference to radio communications. However, there is no guarantee that interference will not occur in a particular installation. If this equipment does cause harmful interference to radio or television reception, which can be determined by turning the equipment off and on, the user is encouraged to try to correct the interference by one or more of the following measures:

- Reorient or relocate the receiving antenna.
- Increase the separation between the equipment and receiver.
- Connect the equipment into an outlet on a circuit different from that to which the receiver is connected.
- Consult the dealer or an experienced radio/TV technician for help.

Unauthorized changes or modification to this system can void the user's authority to operate this equipment.

CAUTION

The normal function of the product may be disturbed by Strong Electro Magnetic Interference. If so, simply reset the product to resume normal operation by following the owner's manual. In case the function could not resume, please use the product in other location.

PRECAUTIONS

PLEASE READ CAREFULLY BEFORE PROCEEDING

Please keep this manual in a safe place for future reference.

Power Supply

Please connect the designated AC adaptor to an AC outlet of the correct voltage.

Do not connect it to an AC outlet of voltage other than that for which your instrument is intended.

Unplug the AC power adaptor when not using the instrument, or during electrical storms.

Connections

Before connecting the instrument to other devices, turn off the power to all units. This will help prevent malfunction and / or damage to other devices.

Location

Do not expose the instrument to the following conditions to avoid deformation, discoloration, or more serious damage:

- Direct sunlight
- Extreme temperature or humidity
- Excessive dusty or dirty location
- Strong vibrations or shocks
- Close to magnetic fields

Interference with other electrical devices

Radios and televisions placed nearby may experience reception interference. Operate this unit at a suitable distance from radios and televisions.

Cleaning

Clean only with a soft, dry cloth.

Do not use paint thinners, solvents, cleaning fluids, or chemical-impregnated wiping cloths.

Handling

Do not apply excessive force to the switches or controls.

Do not let paper, metallic, or other objects into the instrument. If this happens, remove the electric plug from the outlet. Then have the instrument inspected by qualified service personnel.

Disconnect all cables before moving the instrument.

Contents

Panel & Keyboard Description

Front Panel.....	4
Pedal.....	4
Keyboard.....	5
Rear Panel.....	5

Setup

Setup Guide.....	6
------------------	---

Connections

Connecting a pair of Headphones.....	9
Connecting an Audio Equipment.....	9
Connecting an MP3/CD Player.....	9
Connecting a Computer.....	9

Quick Start

Power Supply.....	10
Adjusting the Master Volume.....	10
Playing the Demo.....	10
Playing the Voices.....	10
Playing the Songs.....	11
Recording.....	11

Playing the Voices

Playing a Voice.....	12
Playing Two Voices Simultaneously.....	12
Playing Different Voices with Both Hands.....	12
Voice Volume.....	13
Playing a Voice Demo.....	13
Touch Response.....	13
Transpose.....	14
Tune.....	14
Pedal Resonance.....	14
Metronome.....	14
Tempo.....	15

DSP Effect

Reverb.....	16
Chorus.....	16
D.A.S. (Dynamic Acoustic System).....	16

Song

Play the Songs.....	17
Practice the Songs.....	17

Song Recording

Prepare Recording.....	18
Start Recording.....	18
Stop Recording.....	18
Play back Recording.....	18
Delete Recording.....	18

Duet.....	19
-----------	----

Twinova.....	19
--------------	----

MIDI Out Channel.....	20
-----------------------	----

Beep Tone.....	20
----------------	----

Troubleshooting.....	21
----------------------	----

Specifications.....	21
---------------------	----

Appendices

Voice List.....	22
Song List.....	22
Demo List.....	22
MIDI Implementation Chart.....	23

Panel & Keyboard Description

Front Panel

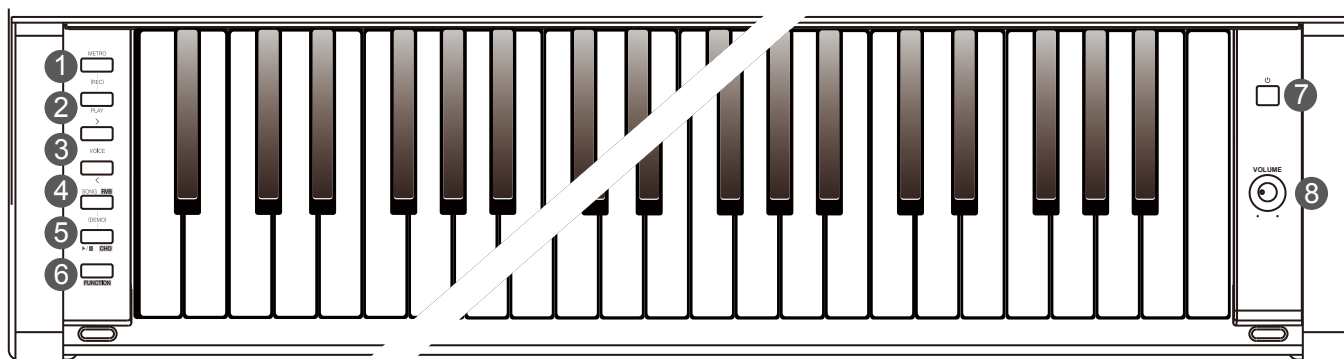

1. [METRO] Button

Press it to turn the Metronome on or off.
Press [METRO] and [PLAY] at the same time to enter Record mode.

2. [PLAY] Button

Start or stop playing a recorded song.
Press [METRO] and [PLAY] at the same time to enter Record mode.

3. [>] / [<] Buttons

Press to adjust the parameters.

4. [SONG RVB] Button

Press it to enter Song mode.
Press and hold [FUNCTION], then press this button to turn Reverb on or off.
Press [SONG RVB] and [▶/■ CHO] at the same time to enter Demo mode.

5. [▶/■ CHO] Button

Press it to start or stop song playback.
Press and hold [FUNCTION], then press this button to turn Chorus on or off.
Press [SONG RVB] and [▶/■ CHO] at the same time to enter Demo mode.

6. [FUNCTION] Button

Press and hold it to access secondary functions of other buttons or keys.

7. [POWER] Switch

Press it to turn the power on or off.

8. [VOLUME] Knob

Adjust the master volume.

Pedal

9. Soft Pedal

Press the soft pedal, the notes played on the keyboard will sound softer.

10. Sostenuto Pedal

Press the sostenuto pedal, the notes played before you step on the pedal will have a sustain effect.

11. Sustain Pedal

Press the sustain pedal, the notes played on the keyboard will have a longer sustain. The sustain pedal also supports half-pedal operation. Perform with the sustain pedal to achieve a smooth sustain effect.

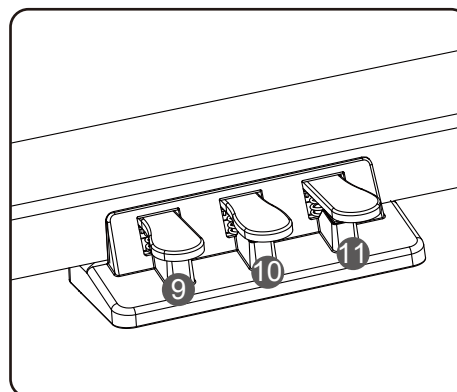

Panel & Keyboard Description

Keyboard

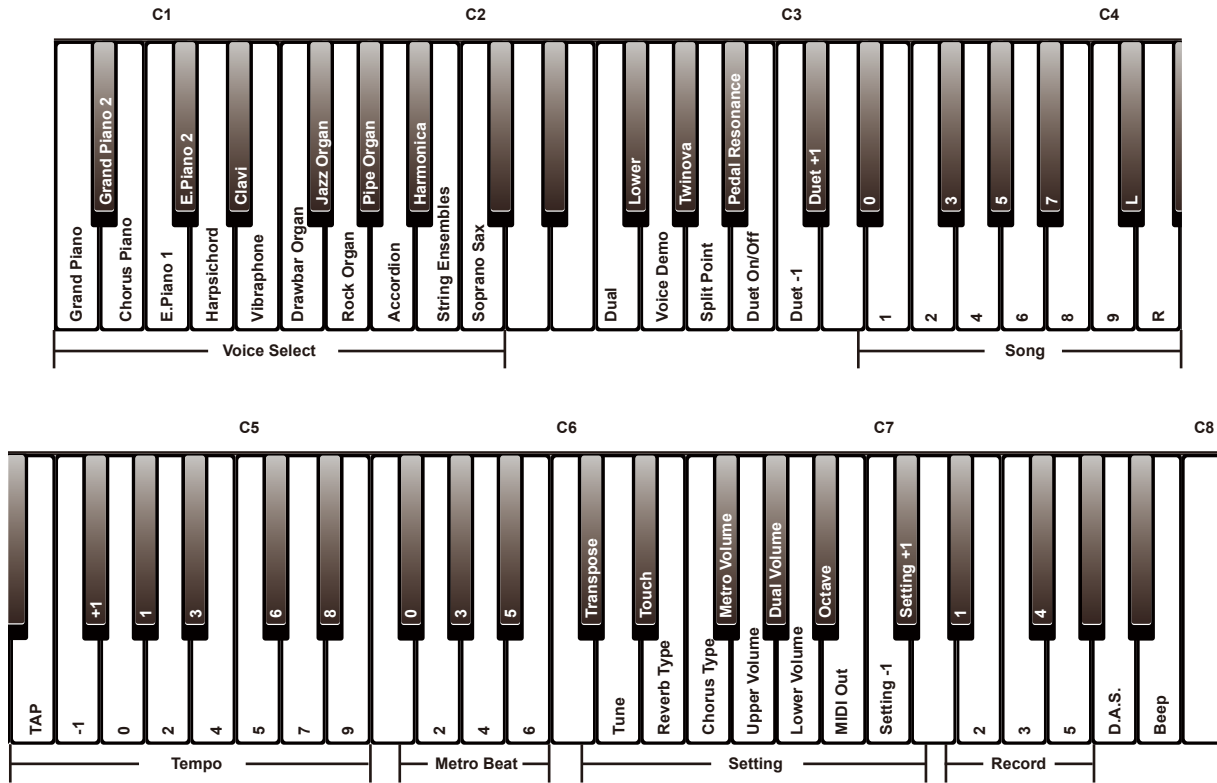

Rear Panel

12. USB Jack

Connect to a computer.

13. AUX OUT Jack

Connect to an external audio equipment.

14. AUX IN Jack

Connect an external audio source, such as an MP3 or CD player.

15. DC IN Jack

Connect the specified power adaptor.

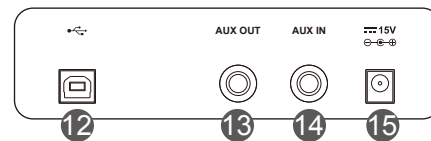

Setup

This section contains information about setting up your instrument and preparing to play. Please go through this section carefully before turning the power on.

Setup Guide

To assemble the stand, you will need a Phillip's screwdriver (not supplied). Check that all the parts listed below are included before proceeding.

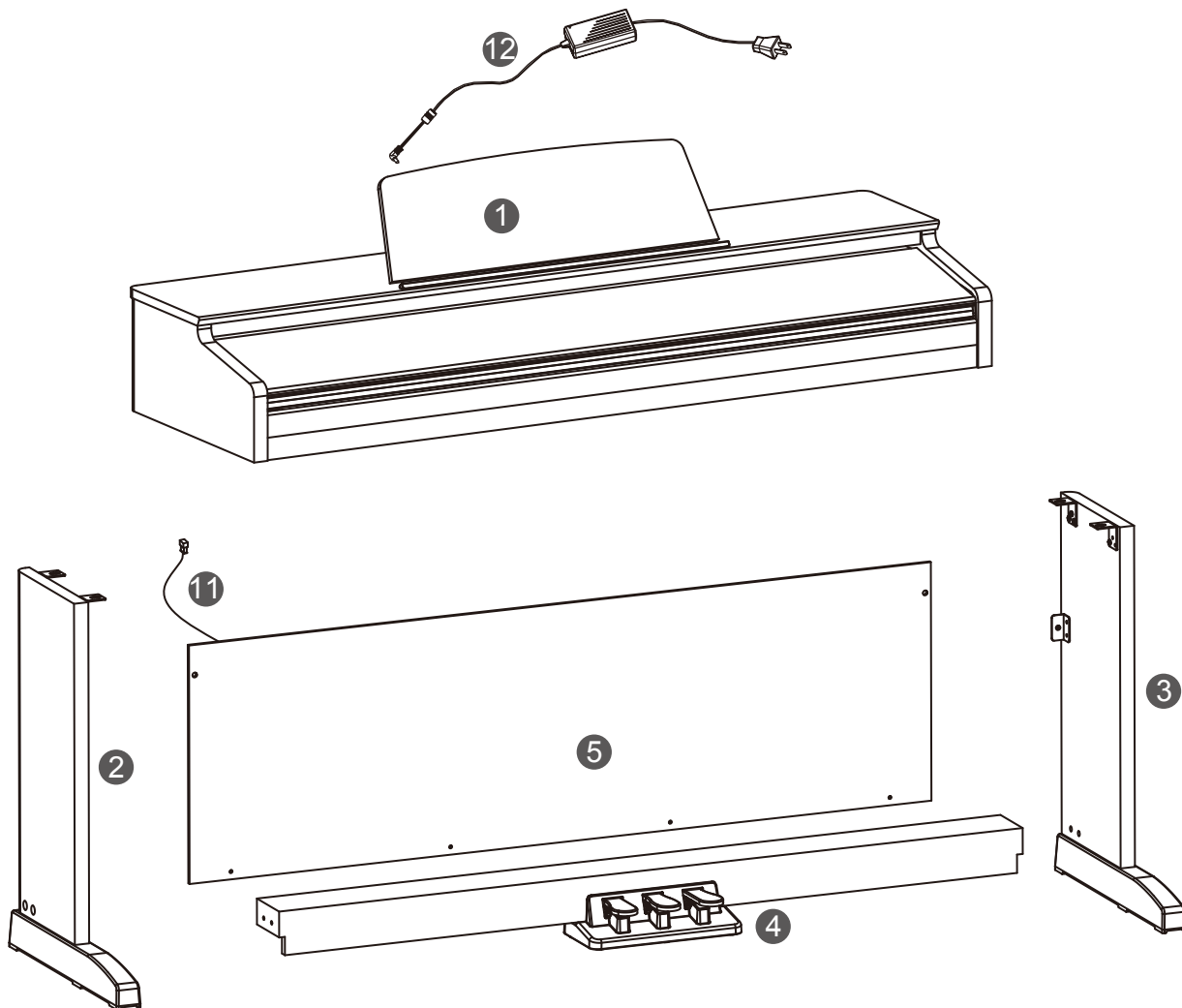

1.	Piano body
2.	Left leg
3.	Right leg
4.	Pedal box
5.	Big back board
6.	Screw M6 X 18 (2 pcs)
7.	Hand screw (4 pcs)
8.	Screw 6 X 50 (4 pcs)
9.	Screw 4 X 15 (4 pcs)
10.	Screw cap (4 pcs)
11.	Pedal cable
12.	AC power adaptor



Setup

- A. Put the pedal box (4) in between the left and right leg components (2&3), use 4 pieces of screws (8) (2 on each side) to fix the legs onto the foot pedal unit, then cover the screw caps (10) on top (2 on each side) (Make sure the components are in the right direction before installing.).

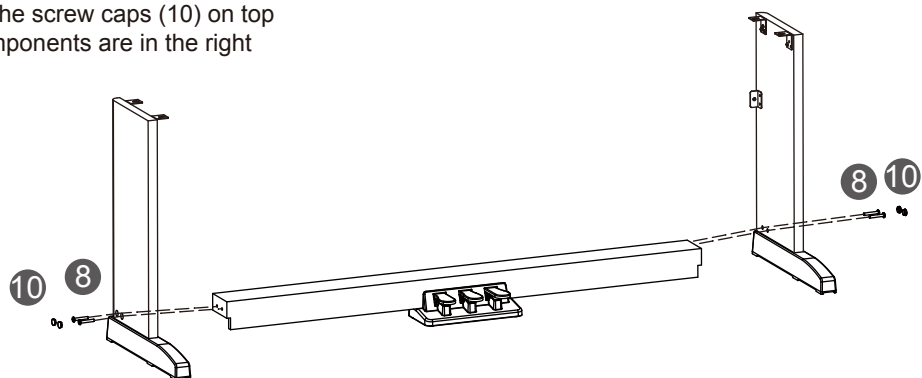

- B. Place the big back board against the stand completed in Step A, then use screw (9) and screw (6) to fix it to the stand.

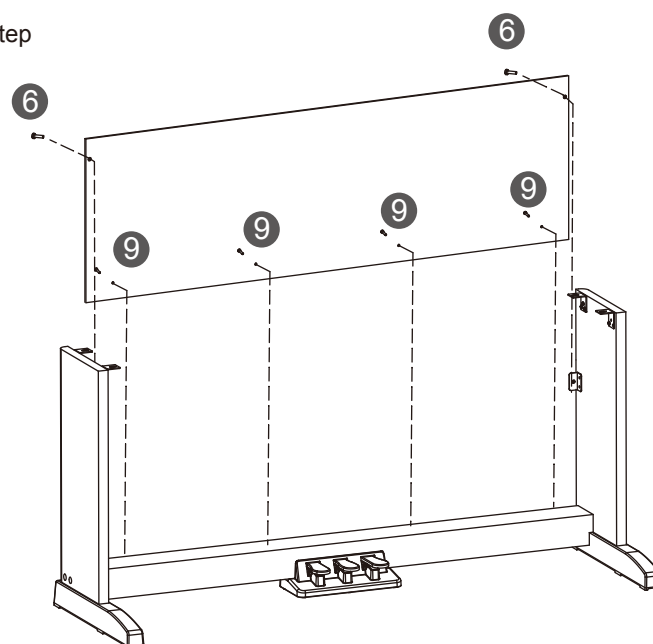

- C. Put the piano body on the top of the assembly finished in Step B, then, use hand screw (7) to fix it.

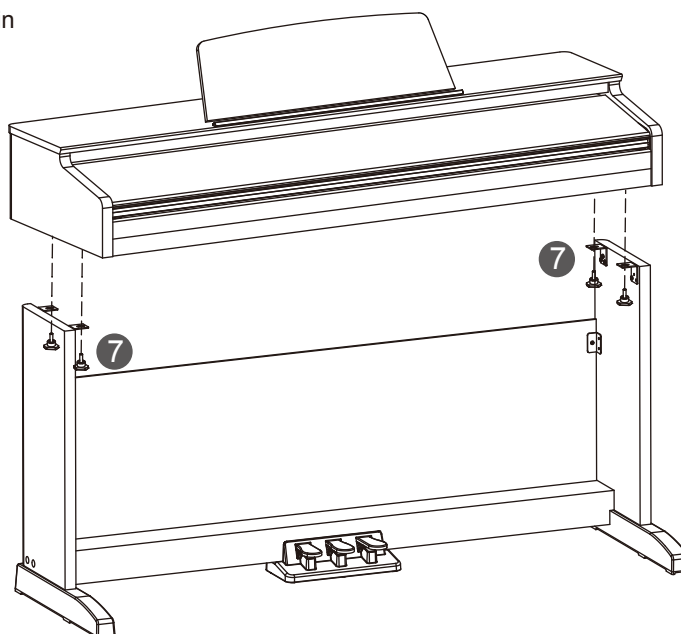

Setup

D. Connect the pedal cable to the pedal jack at the rear bottom of the piano. The setup is completed, now the piano is ready to connect to power supply.

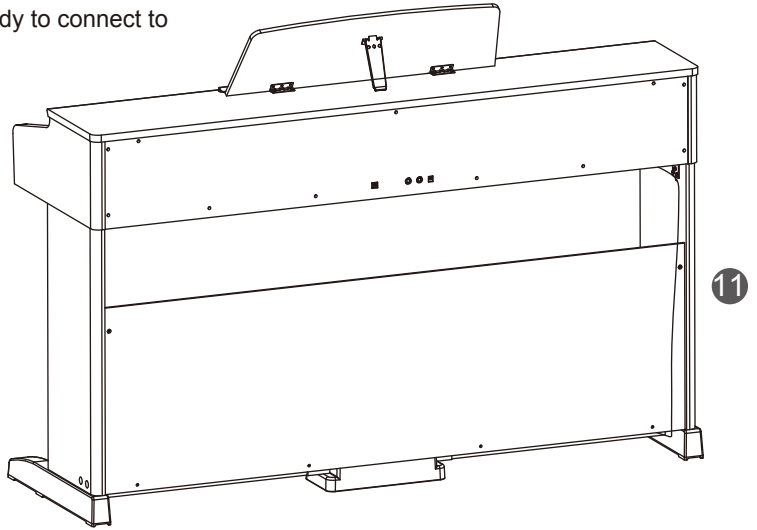

Connections

Connecting a pair of Headphones

Plug a pair of standard stereo headphones here for private practice or late-night playing.

Jack 1: When headphones are connected, sound can be heard from the headphones and speakers.

Jack 2: When headphones are connected, the internal speakers will be muted, and the sound can only be heard from the headphones.

Note:

To avoid the risk of hearing loss, do not use headphones at high volume level for a long period of time.

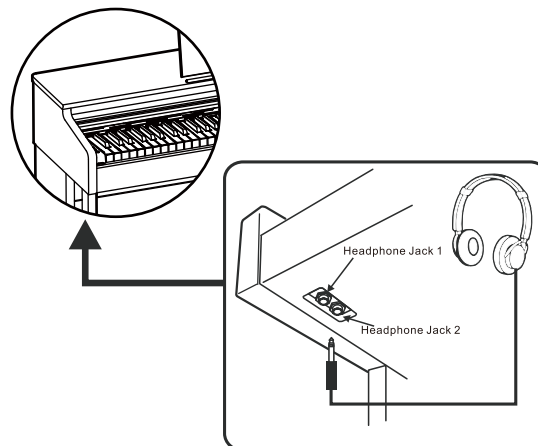

Connecting an Audio Equipment

The AUX OUT jack delivers the output of the instrument to external audio equipment such as a keyboard amplifier, stereo sound system, mixing console, or recording interface.

Use an audio cable to connect the AUX OUT jack of the instrument to the INPUT jack of the external audio equipment.

Notes:

1. Turn off the power to all devices before connecting or disconnecting external equipment.
2. To avoid damaging the speakers, set the master volume level to minimum before turning on the power.

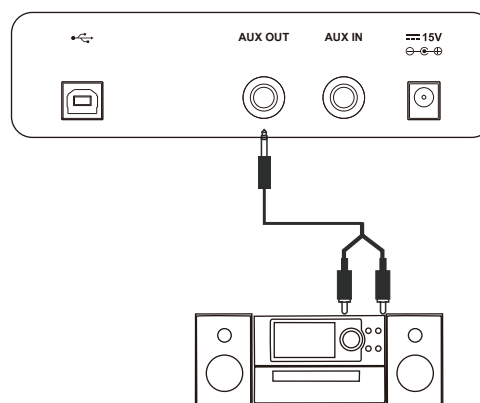

Connecting an MP3/CD Player

The AUX IN jack receives audio signals from an external audio source such as an MP3 or a CD player.

Use an audio cable to connect the AUX IN jack of the instrument to the OUTPUT jack of an MP3/CD player. The instrument's speakers will play the music transmitted from the external player, and you can play along.

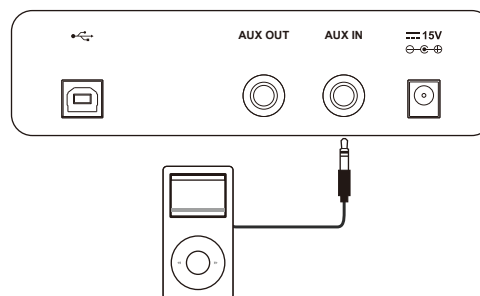

Connecting a Computer

Use a standard USB cable to connect the USB jack of the instrument to the USB port of a computer.

With USB, you can save a keyboard performance to the computer or use the instrument to play back music played on the computer.

Note:

Do not set the USB MIDI device to be both input and output simultaneously when configuring the software on your computer. Otherwise, the sound will be overlapped when playing the keyboard.

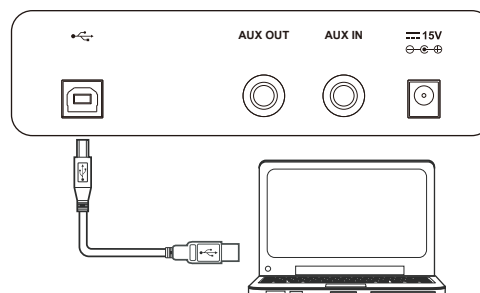

Quick Start

Power Supply

1. Before connecting to power supply, please set the [POWER] switch to “OFF” and set the master volume level to minimum.
2. Connect the power adaptor to the DC IN jack on the rear panel.
3. Plug the power adaptor into an appropriate AC outlet.
4. Press the [POWER] switch. The button indicator lights up, indicating the instrument is powered on.
5. When you are ready to turn the instrument off, press and hold the [POWER] switch for a second. The button indicator will turn off.

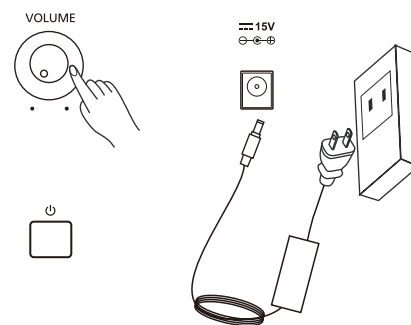

Notes:

1. In order to save energy, the instrument will automatically shut down after 30 minutes when not in use. To turn off this function, press and hold the key A0 (the first key to the left of the keyboard), then turn on the power.
2. For your safety, please unplug the instrument when it is not in use or during a thunderstorm.

Adjusting the Master Volume

Rotate the [VOLUME] knob clockwise to increase the master volume or counter-clockwise to decrease it. Adjust to set the desired volume level.

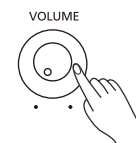

Note:

If the speakers do not produce sound, please check if the master volume is set too low or if headphones are plugged into Jack 2.

Playing the Demo

The instrument features a professional demo. Please refer to the Demo List for details.

1. Press [SONG RVB] and [▶/■ CHO] buttons at the same time to start playing the demo. Repeat this operation to stop the demo.
2. During demo playback, pressing the [▶/■ CHO] button will stop playing and exit Demo mode.

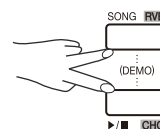

Playing the Voices

The instrument features a variety of exceptionally realistic voices. Please refer to the **Voice List** for details.

1. Press the [>]/[<] buttons to select a desired voice.
2. Alternatively, press and hold [FUNCTION], then press one of the [A0] – [C2] keys to select a voice.

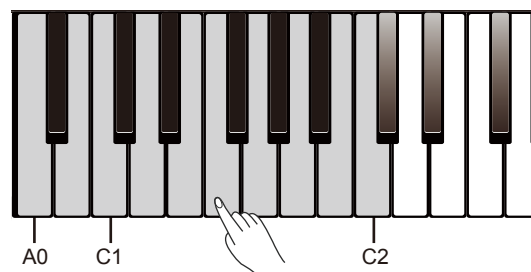

Playing the Songs

The instrument features a variety of preset songs. Please refer to the Song List for details.

1. Press the [**SONG R/B**] button to enter Song mode and start playing all songs in a loop.
2. Press the [>]/[<] buttons to select a desired song.
3. Alternatively, press and hold [**FUNCTION**], then press the [**D#3**] – [**C4**] keys to select a specific song.
4. During song playback, pressing the [**▶/■ CHO**] button will stop the playback. Pressing this button again will play the current song in a loop.

Note:

When using the [**D#3**] – [**C4**] keys to select a song, you need to press 2 keys total. For example, press and hold [**FUNCTION**], then press [**D#3**] and [**B3**] in sequence to select the “08” song.

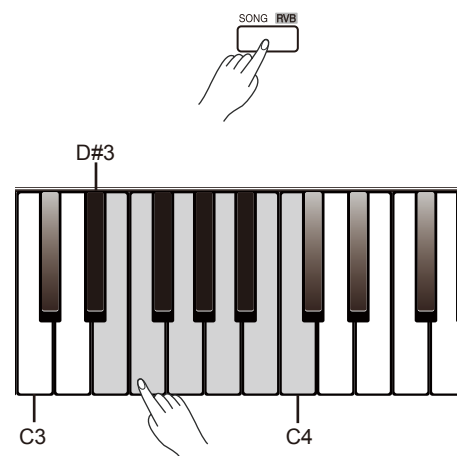

Recording

You can record and save your keyboard performance as a user song on the instrument.

1. Press [**METRO**] and [**PLAY**] buttons at the same time, then press one of the [**D#7**] – [**G7**] keys to select a user song to which the recording will be saved. The button indicators for [**METRO**] and [**PLAY**] will stay lit.
2. Now it enters recording standby mode. The button indicator for [**▶/■ CHO**] will blink. Now you can set the desired voice, tempo etc. for recording.
3. Press the [**▶/■ CHO**] button or simply play the keyboard to start recording.
4. During recording, if you press [**METRO**] and [**PLAY**] buttons at the same time, recording will stop and be saved. The button indicators for [**METRO**] and [**PLAY**] will turn off.
5. To play back a recorded song, press and hold [**PLAY**], then press one of the [**D#7**] – [**G7**] keys to select a song.
6. After selecting a recorded song, the button indicator for [**PLAY**] will light up. Press this button again to play back the recording.
7. To stop the playback, press the [**PLAY**] button.
8. After selecting a recorded song for playback, if you press [**METRO**] and [**PLAY**] buttons at the same time, it will delete the selected song.

Note:

If you do not select a user song for recording or playback, it will automatically use the same user song in the last operation. When you restart the instrument, it will select the first user song by default.

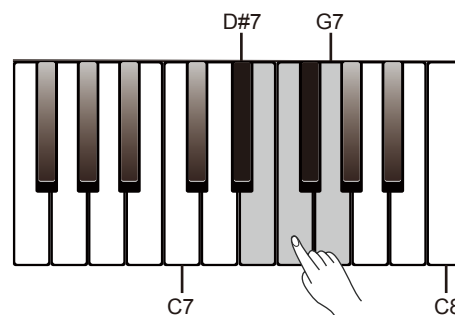
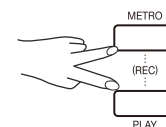

Playing the Voices

The instrument features a variety of exceptionally realistic voices. Please refer to the **Voice List** for details.

Playing a Voice

1. Press the [>]/[<] buttons to select a desired voice.
2. Press and hold [FUNCTION], then press one of the [A0] – [C2] keys to select a voice. Each of these keys has been assigned a preset voice.
3. Play the keyboard to use the selected voice for performance.

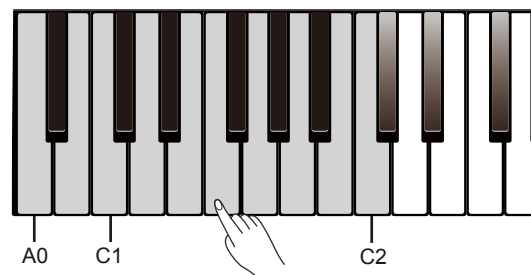

Playing Two Voices Simultaneously

The Dual function allows two different voices to be layered together, creating a more full and rich sound.

1. Select a main voice (upper voice).
2. Turn on the dual function. Press and hold [FUNCTION], then press the [F2] key to turn on the dual function. The default dual voice is Strings.
3. Select a dual voice. Press and hold [FUNCTION], then press the [F2] key once and then press one of the [A0] – [C2] keys to select a dual voice.
4. Play the voices. Play the keyboard and you will hear two different voices playing together, just like two different instruments being played at the same time.
5. Turn off the dual function. Press and hold [FUNCTION], then press the [F2] key to turn off the dual function.

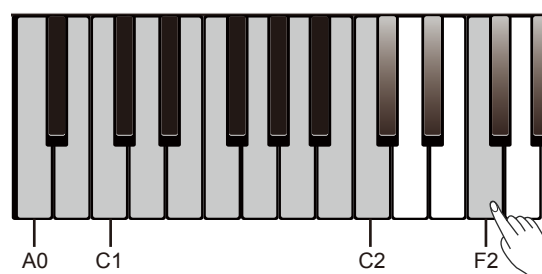

Note:

When the lower and dual functions are in use, only the right hand area will play the layered voices.

Playing Different Voices with Both Hands

The Lower function splits the keyboard into two areas so as to create different voices for each of your hands. The left hand voice is the lower voice.

1. Select a main voice (upper voice).
2. Turn on the lower function. Press and hold [FUNCTION], then press the [F#2] key to turn on the lower function. The default lower voice is Strings.
3. Select a lower voice. Press and hold [FUNCTION], then press the [F#2] key once and then press one of the [A0] – [C2] keys to select a lower voice.
4. Play the voices. Play the keyboard with both hands and you will hear two different voices from the left and right hand areas.
5. Turn off the lower function. Press and hold [FUNCTION], then press the [F#2] key to turn off the lower function.

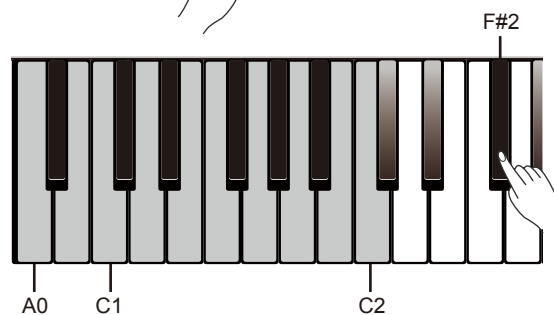
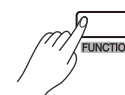

Playing the Voices

Split point

The key that splits the keyboard into the left and right hand areas is called "split point". The default split point is F#3 (34), however, you can assign it to any other key.

1. Press and hold [FUNCTION], then press the [A2] key once, and then tap a key on the keyboard to assign the split point to that key.
2. Release the [FUNCTION] button to exit the edit mode.

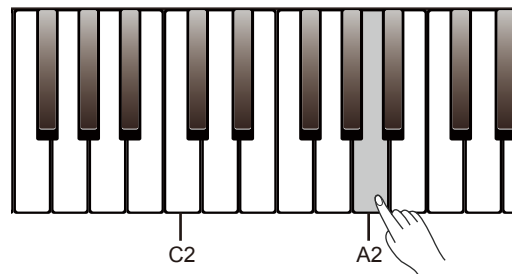

Voice Volume

You can adjust separately the volume of the upper voice, the dual voice and the lower voice.

1. Press and hold [FUNCTION], then press the [G6] key to edit the upper voice volume.
2. In edit mode, press and hold [FUNCTION], then press the [C7]/[C#7] keys to adjust the volume range from 0 to 15.
3. In edit mode, press and hold [FUNCTION], then press the [C7] and [C#7] keys at the same time to reset the volume to default.
4. Set the dual voice volume and lower voice volume in the same way. Press and hold [FUNCTION], then press the [G#6] key to edit the dual voice volume, then use the [C7]/[C#7] keys to adjust the volume. Press and hold [FUNCTION], then press the [A6] key to edit the lower voice volume, then use the [C7]/[C#7] keys to adjust the volume.

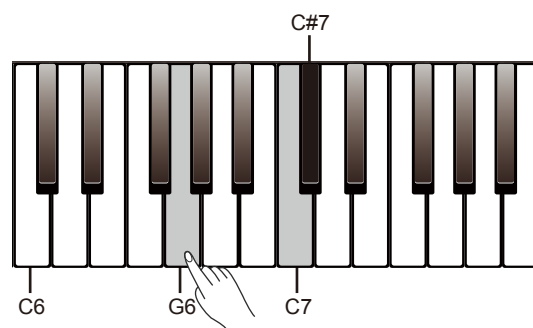

Playing a Voice Demo

1. In Voice mode, press and hold [FUNCTION], then press the [G2] key to start playing the current upper voice demo.
2. During demo playback, press and hold [FUNCTION], then press the [G2] key again to stop playing. Alternatively, press the [▶/■ CHO] button to stop the playback.

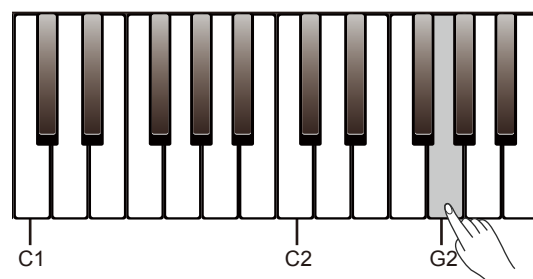

Touch Response

The touch response feature allows you to expressively control the voice level based on your playing dynamics, just as on an acoustic instrument. There are 5 types of touch curves (Off, 1 – 5). The default setting is 3.

1. Press and hold [FUNCTION], then press the [D#6] key to edit the touch setting.
2. In edit mode, press and hold [FUNCTION], then press the [C7]/[C#7] keys to change the setting.
3. In edit mode, press and hold [FUNCTION], then press the [C7] and [C#7] keys at the same time to restore the default setting.

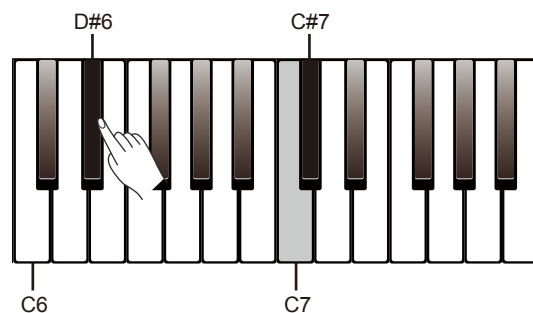

Touch Setting	Description
OFF	Fixed
1	Soft 1
2	Soft 2
3	Medium
4	Hard 1
5	Hard 2

Playing the Voices

Transpose

The transpose function allows the overall pitch of the instrument to be transposed up or down by a maximum of one octave in semitone steps.

1. Press and hold [FUNCTION], then press the [C#6] key to edit the transpose setting.
2. In edit mode, press and hold [FUNCTION], then press the [C7]/[C#7] keys to adjust the transpose range from -12 to +12.
3. In edit mode, press and hold [FUNCTION], then press the [C7] and [C#7] keys at the same time to restore the default setting "00".

Notes:

1. For example, if you set the transpose value to -05 or +07, you will hear "G" pitch when playing the "C" keys.
2. Transpose setting applies to the accompaniment and the entire keyboard voice.

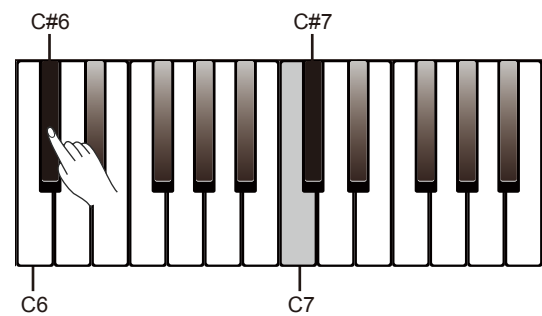

Tune

The tune function adjusts the pitch of the entire keyboard in 2-cent increments over a range of ± 50 (100 cents).

1. Press and hold [FUNCTION], then press the [D6] key to edit the tune setting.
2. In edit mode, press and hold [FUNCTION], then press the [C7]/[C#7] keys to change the setting.
3. In edit mode, press and hold [FUNCTION], then press the [C7] and [C#7] keys at the same time to restore the default setting "00".

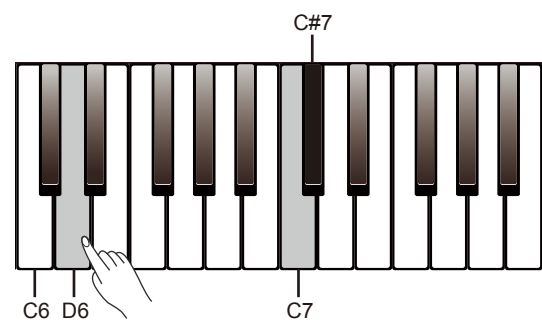

Operation	Description
C7	Lower the overall pitch by 1.
C#7	Raise the overall pitch by 1.
C7 + C#7	Restore the default tune value.

Pedal Resonance

When a piano voice is selected, pressing the sustain pedal will add string resonance effect to the notes you play. The string resonance effect faithfully recreates the resonance from the strings and soundboard of an acoustic grand piano.

1. Press and hold [FUNCTION], then press the [A#2] key to turn this function on or off.
2. Pedal resonance is turned on by default when you turn on the power.

Notes:

1. Chorus effect will be disabled when pedal resonance is in use.
2. There may be a slight pause in the sound if you switch pedal resonance on/off while performing.

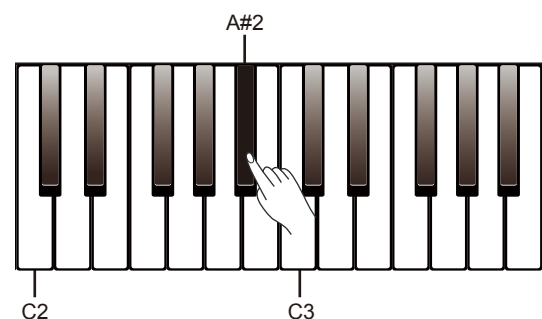

Metronome

The metronome provides a steady beat to help you practice at a preset tempo.

Turn the metronome on or off.

Press the [METRO] button to turn the metronome on or off.

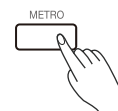

Playing the Voices

When metronome is in use, the button indicator for [▶/■ CHO] will flash in sync with the metronome sound. (Red for downbeat and blue for upbeat). To adjust the metronome tempo, please refer to Tempo for details.

Set the metronome beat.

The instrument provides 6 beat types: 0, 2 – 6.

When metronome is in use, press the [>]/[<] buttons to change the beat type.

Alternatively, press and hold [FUNCTION], then press one of the [F#5] – [B5] keys to select a beat type.

Set the metronome volume.

1. Press and hold [FUNCTION], then press the [F#6] key to edit the metronome volume.
2. In edit mode, press and hold [FUNCTION], then press the [C7]/[C#7] keys to adjust the volume range from 0 to 15.
3. In edit mode, press and hold [FUNCTION], then press the [C7] and [C#7] keys at the same time to reset the volume to default.

Note:

The metronome is not available in song mode.

Tempo

You can change the tempo over the range from 30 to 280.

1. Press and hold [FUNCTION], then press the [F4]/[F#4] keys to change the tempo.
2. Press and hold [FUNCTION], then press the [F4] and [F#4] keys at the same time to restore the default tempo “120”. In Song mode, it will reset to the default song tempo.
3. Press and hold [FUNCTION], then press the [>]/[<] buttons to adjust the tempo in the step of 10.
4. Press and hold [FUNCTION], then use the [G4] – [E5] keys to enter a tempo value. For example, pressing [A4],[G#4] and [B4] in sequence will enter a tempo value of 214.
5. Press and hold [FUNCTION], then tap the [E4] key twice to get the desired tempo. The instrument will start the metronome sound at the tapping speed.

Operation	Description
[F4]/[F#4] keys	Increase/decrease the tempo value by 1.
[F4]+[F#4] keys	Restore the default tempo.
[>]/[<] buttons	Increase/decrease the tempo value in the step of 10.
[G4] – [E5] keys	Enter a specific tempo value (pressing 3 keys).
[E4] key	Set the tempo at the tapping speed.

Notes:

1. When using [G4] – [E5] keys to set the tempo value, you need to press 3 keys total. For example, press [G4], [C#5] and [B4] in sequence to enter a tempo value of 64.
2. In standby mode, if the times you tap the [E4] key equal to that of the metronome beat, the instrument will start the metronome sound at the speed of the last two tapping.

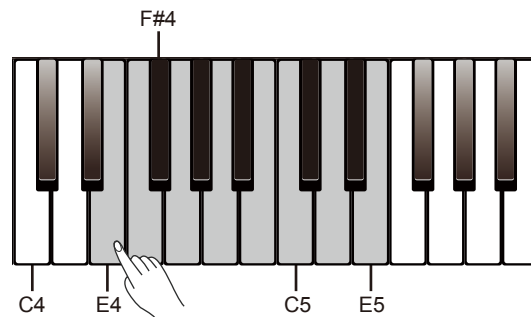
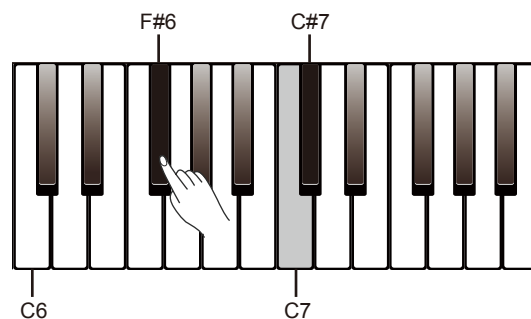
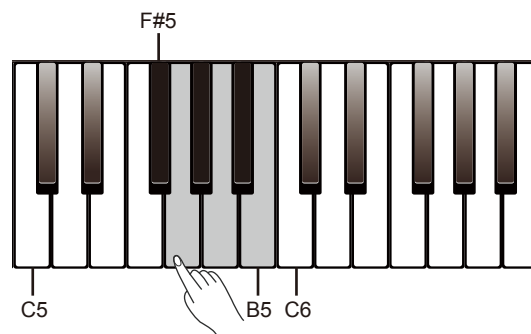

DSP Effect

The DSP effects will add ambiance and depth to your performance in a variety of ways.

Reverb

1. Press and hold [FUNCTION], then press the [SONG **RVB**] button to turn reverb effect on or off.
2. Press and hold [FUNCTION], then press the [E6] key to edit the reverb setting.
3. In edit mode, press and hold [FUNCTION], then press the [C7]/[C#7] keys to select a reverb type from 1 to 5.
4. In edit mode, press and hold [FUNCTION], then press the [C7] and [C#7] keys at the same time to restore the default reverb type "3 Church".

Reverb Type	Description
1	Room
2	Hall
3	Church
4	Delay
5	Pan delay

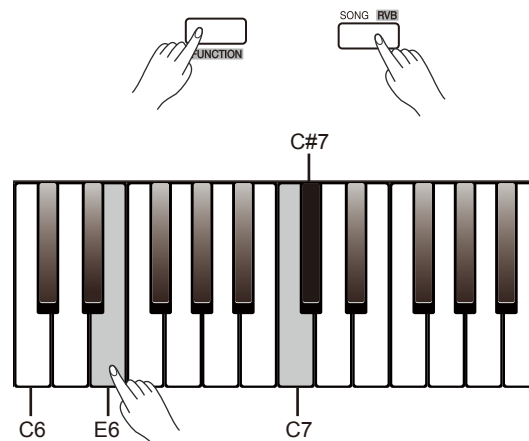

Chorus

1. Press and hold [FUNCTION], then press the [▶/■ **CHO**] button to turn chorus effect on or off.
2. Press and hold [FUNCTION], then press the [F6] key to edit the chorus setting.
3. In edit mode, press and hold [FUNCTION], then press the [C7]/[C#7] keys to select a chorus type from 1 to 5.
4. In edit mode, press and hold [FUNCTION], then press the [C7] and [C#7] keys at the same time to restore the default chorus type "Chorus 2".

Chorus Type	Description
1	Chorus 1
2	Chorus 2
3	Chorus 3
4	Flanger
5	Rotary

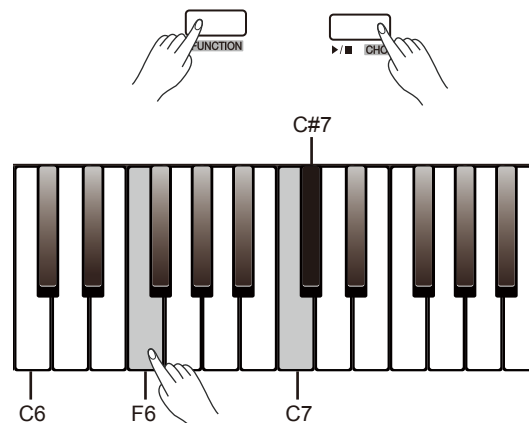

D.A.S. (Dynamic Acoustic System)

The loudness of sound perceived by human ears over the frequency spectrum is different. As the audio volume decreases, human ears' sensitivity to extreme high and low frequencies will decline. As a result, the audio may seem to become 'thin' sounding at low volumes, losing bass and treble.

The D.A.S. function will dynamically adjust the sound of the instrument according to the overall volume for better sound balance, giving you a more clear, natural and rich sound.

Turn the D.A.S. function on or off

Press and hold [FUNCTION], then press the [A7] key to turn D.A.S. on or off.

Note:

The D.A.S. function is turned on by default when you turn on the power.

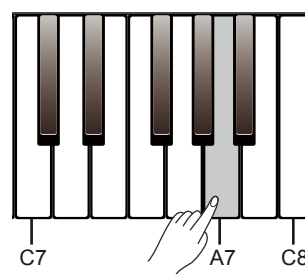
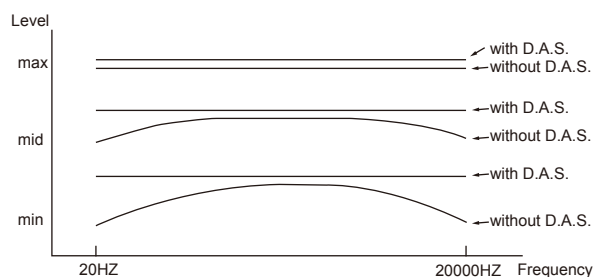

Song

The instrument features a variety of preset songs. Please refer to the Song List for details.

Play the Songs

1. Play all songs in a loop.

Press the [**SONG RVB**] button to start playing all preset songs in a loop. The button indicator lights up.



2. Play the selected song in a loop.

When song playback stops, press the [**▶/■ CHO**] button to play the current song in a loop.

3. Select a song.

During song playback, press the [>]/[<] buttons to select a desired song.

Alternatively, press and hold [**FUNCTION**], then use the [**D#3**] – [**C4**] keys to select a specific song.

4. Stop the playback.

During song playback, press [**SONG RVB**]/[**▶/■ CHO**] buttons to stop the song.

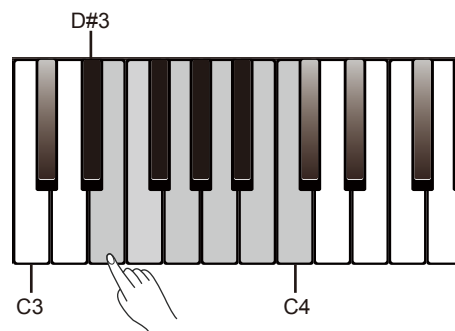

Note:

When using the [**D#3**] – [**C4**] keys to select a song, you need to press 2 keys total. For example, press and hold [**FUNCTION**], then press [**D#3**] and [**B3**] in sequence to select the “08” song.

Practice the Songs

All preset songs can be practiced with melody-off.

1. Press and hold [**FUNCTION**], then press the [**C#4**] key to mute the left hand melody. You can now practice the left hand melody of the song. Repeat this operation to activate the left hand melody.

2. In the same way, press and hold [**FUNCTION**], then press the [**D4**] key to mute the right hand melody. You can now practice the right hand melody of the song.

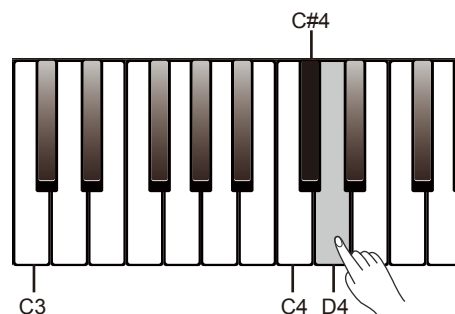
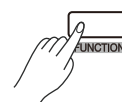

Song Recording

You can record and save your keyboard performance as a user song on the instrument, and then play it back.

Prepare Recording

1. Before recording starts, you need to select a user song to which the recording will be saved. Press [METRO] and [PLAY] buttons at the same time, then press one of the [D#7] –[G7] keys to select a user song.
2. Now it enters recording standby mode. The button indicator for [▶/■ CHO] will blink. Now you can set the desired voice, tempo etc. for recording.

Start Recording

In recording standby mode, press the [▶/■ CHO] button or simply play the keyboard to start recording. The button indicators for [METRO] and [PLAY] will stay lit.

Note:

If the current user song has data, the data will be overwritten after recording.

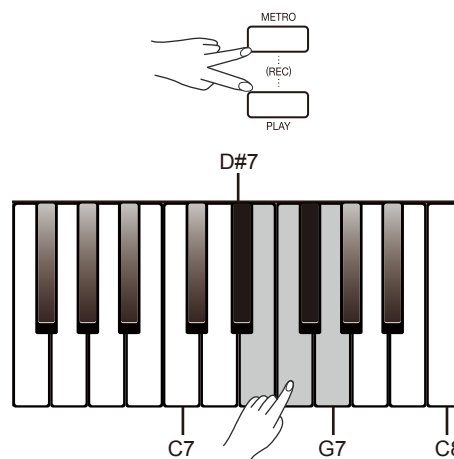

Stop Recording

1. During recording, if you press [METRO] and [PLAY] buttons at the same time, recording will stop and be saved. The button indicators for [METRO] and [PLAY] will turn off.
2. During recording, if the memory gets full, recording will automatically stop and be saved. The button indicators for [METRO] and [PLAY] will turn off.

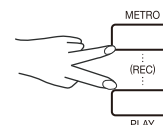

Play back Recording

1. After recording, press and hold [PLAY], then press one of the [D#7] –[G7] keys to select a recorded song.
2. Press the [PLAY] button to start playback. The button indicator will stay lit.
3. To stop playback, press the [PLAY] button again. The button indicator turns off.

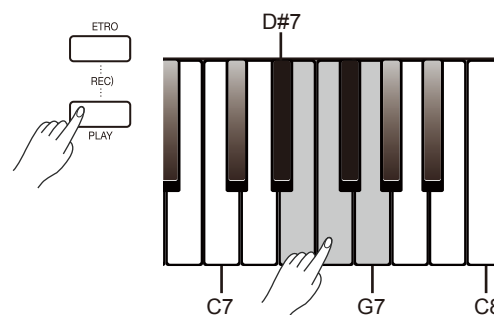

Delete Recording

1. Delete all user songs.
Press and hold [METRO] and [PLAY] buttons, then turn on the power. This operation will delete all user songs.
2. Delete a specific user song.
When selecting a user song to play back, if you press [METRO] and [PLAY] buttons at the same time, it will delete the selected user song.

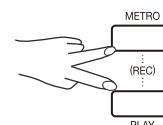

Note:

The saved user songs will not be lost after power off.

Duet

The Duet function will enrich your performance. Simply play a chord with your left hand, and the instrument will play a preset duet pattern and produce a beautiful melody.

Turn the duet function on or off.

Press and hold [FUNCTION], then press the [B2] key to turn on the duet function on or off.

Select a duet pattern.

Press and hold [FUNCTION], then press the [C3]/[C#3] keys to select a duet pattern. There are 32 duet patterns. The default setting is "01".

Note:

Each voice is matched with a preset duet pattern, so when you change a voice, the default duet pattern will change as well.

Set the duet split point.

When duet function is in use, the keyboard will be split into two areas. You can play chords in the left hand area, and play melody in the right hand area. The default split point is the same as in the lower function: F#3 (34). You can assign the split point to any other key.

1. Press and hold [FUNCTION], then press the [A2] key to edit the split point, and then tap a key on the keyboard to assign the split point to that key.

2. Release the [FUNCTION] button to exit the edit mode.

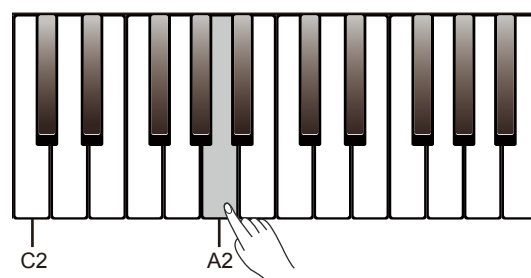
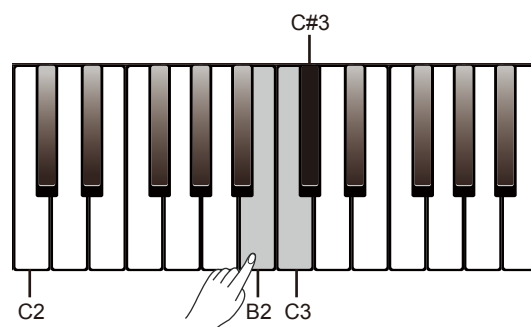

Twinova

The Twinova function splits the keyboard into two areas with the same pitch and voice, for the convenience of playing together with a friend or instructor.

Turn the Twinova function on or off.

Press and hold [FUNCTION], then press the [G#2] key to turn Twinova function on or off.

The default split point is E3 (32). In Twinova mode, the dual and lower functions are not available.

Select a voice for Twinova.

The upper voice selected before entering Twinova will become the default voice for both areas. Press the [>]/[<] buttons to change the voice.

Alternatively, press and hold [FUNCTION], then press one of the [A0] – [C2] keys to select a voice.

Set the split point for Twinova.

1. In Twinova mode, press and hold [FUNCTION], then press the [A2] key to edit the split point, and then tap one of the [C3] – [C6] keys to assign the split point.

2. Release the [FUNCTION] button to exit the edit mode.

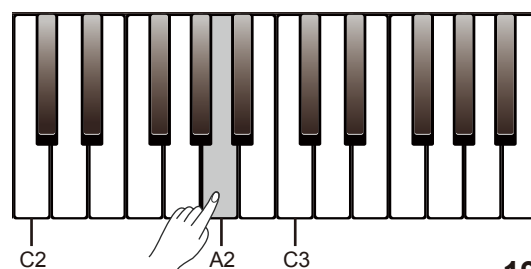
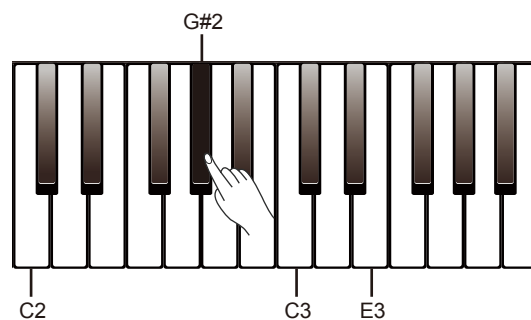

Twinova

Set the octave for Twinova.

This function will shift the pitch of the keyboard up or down by one octave. This function is available only in Twinova mode, and the octave for both areas will be adjusted together. The octave setting will be reset to default when you exit Twinova mode.

1. Press and hold [FUNCTION], then press the [A#6] key to edit the octave setting.
2. In edit mode, press and hold [FUNCTION], then press the [C7]/[C#7] keys to change the setting.
3. In edit mode, press and hold [FUNCTION], then press the [C7] and [C#7] keys at the same time to restore the default setting "0".

Note:

Twinova function is not available in song mode and demo mode.

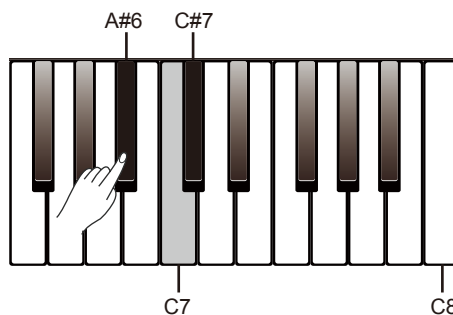

MIDI Out Channel

1. Press and hold [FUNCTION], then press the [B6] key to edit the MIDI Out channel setting.
2. In edit mode, press and hold [FUNCTION], then press the [C7]/[C#7] keys to change the setting from 01 to 16.
3. In edit mode, press and hold [FUNCTION], then press the [C7] and [C#7] keys at the same time to restore the default setting "01".

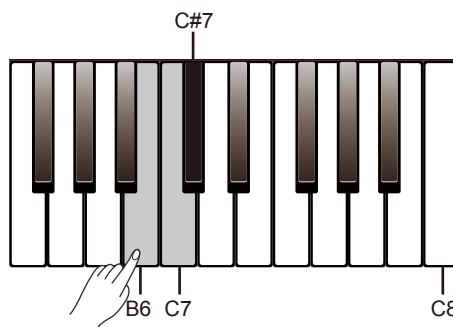

Beep Tone

The instrument will produce a sound when using the keyboard to change a setting. This function is turned on by default.

Press and hold [FUNCTION], then press the [B7] key to turn the beep tone function on or off.

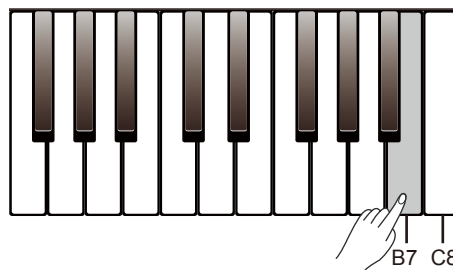

Troubleshooting

Problem	Possible Cause and Solution
The speakers produce a pop sound whenever the power is turned ON/OFF.	This is normal and no cause for alarm.
Speakers do not produce sound when the keyboard is played.	Check if the master volume is set too low or if headphones are plugged into Jack 2.
There is noise when I use a mobile phone.	Using a mobile phone in close proximity to the instrument may produce interference. To prevent this, turn off the mobile phone or keep it away from the instrument when using.
When connecting to computer, the instrument cannot be recognized.	Check if the USB cable is firmly connected. Try connecting another USB port on the computer. This instrument is plug and play and should work without installing a driver.

Specifications

Keyboard	
Keyboard	88 Graded Hammer-Action Keys
Touch Response	5 types, Off
Voices	
Polyphony (max.)	128
Voices	16
Layer	Left, Right1, Right2
Split	Yes
Duo (Twinova)	Yes
Effects	
Reverb	5 types, Off
Chorus	5 types, Off
Performance Enhance	
Duet	32 types
Song & Recording	
Music Library	60 preset songs, with L/R hand learning
Sequencer	5 user songs
Demo	1 piano demo, 16 voice demos
Pitch Adjustment	
Transpose	-12 – +12
Octave	-1 – +1 (Twinova)
Tuning	-50 – +50

Other Functions	
Metronome	0, 2 – 6
Tempo	30 – 280
Other control	Voice demo, MIDI out channel, D.A.S.
Connections	
Interaction & Expansion	USB MIDI, PC software
Phones	2 standard stereo
Pedals	Sustain, Soft, Sostenuto
USB	USB MIDI
Input	Standard stereo
Output	Standard stereo
Power Supply	
Power	DC15V / 2500mA
Power Off Protection	Yes
Amplifiers & Speakers	
Amplifiers	20W x 2
Speakers	10W x 2
Dimensions & Weight	
Dimensions LWH (mm)	1320 x 440 x 815
Weight (kg)	38.5

* All specifications and appearances are subject to change without notice.

Voice List

No.	Voice Name
1	Grand Piano
2	Grand Piano 2
3	Chorus Piano
4	E.Piano 1
5	E.Piano 2
6	Harpsichord
7	Clavi
8	Vibraphone

9	Drawbar Organ
10	Jazz Organ
11	Rock Organ
12	Pipe Organ
13	Accordion
14	Harmonica
15	String Ensembles
16	Soprano Sax

Song List

No.	Song Name
1	The Entertainer
2	Rialto Ripples (Rag)
3	Neapolitan Song
4	Waltzes
5	Turkish March
6	Schos Doll's Dance No. 2
7	Minuet In D Major
8	Inquietude
9	Italian Polka
10	Moment Musical
11	Prelude In C-Sharp Major
12	The Happy Farmer
13	The Rag-Time Dance
14	Piano Sonata In C Major, K.330. III
15	Mazurka
16	Prelude In E Major
17	Piano Sonata In A Major, K.331. I
18	Waltz For Piano In G-Sharp Minor
19	Gavotte
20	L' Arabesque
21	Austria Variation
22	Schos Doll's Dance No. 7
23	To A Wild Rose
24	Gavotte I
25	Waltz
26	Minuet In G Major (BWV Anh. 116)
27	Innocence
28	Tchaikovsky Waltz
29	Salut d' Amour
30	Barcarolle

31	Robot Doll
32	Consolation
33	2-Part Invention #13 In A Minor.B.W. Iii
34	Minuet In G Major (BWV Anh. 114)
35	Barcarolle
36	Norwegian Dance No.2
37	Moseta Dance
38	The Small Gathering
39	The Return
40	The Wagtail
41	Bulie Dance
42	Tender Blossom
43	Grace
44	Cherish The Memories
45	Chopsticks
46	Four Little Swans
47	Progress
48	Eclogue
49	The Limpid Stream
50	Brave Cavalier
51	The Chatterbox
52	Tarantella
53	Frankness
54	Tender Grieving
55	The Farewell
56	The Chase
57	Habanera
58	Prelude In C Major
59	Fountain
60	Fur Elise

Demo List

No.	Song Name
1	Fantasia

MIDI Implementation Chart

Function		Transmitted	Recognized	Remarks
Basic Channel	Default	1ch	ALL	
	Changed	1–16ch	1–16ch	
Mode	Default	x	3	
	Messages	x	3	
	Altered	*****	x	
Note Number	Note	0–127	0–127	
	:True voice	*****	0–127	
Velocity	Note on	○ 9nH,V=1–127	○ 9nH,V=1–127	
	Note off	x (9nH,V=0)	○(9nH,V=0; 8nH,V=0–127)	
After Touch	key's	x	x	
	Ch's	x	x	
Pitch Bend		x	○	
Control Change	0	○	○	Bank Select
	1	x	○	Modulation
	5	x	○	Portamento Time
	6	○	○	Data Entry
	7	○	○	Volume
	10	x	○	Pan
	11	x	○	Expression
	64	○	○	Sustain Pedal
	65	x	○	Portamento ON/OFF
	66	○	○	Sostenuto Pedal
	67	○	○	Soft Pedal
	80	○	○	Reverb Program
	81	○	○	Chorus Program
	91	○	○	Reverb Level
	93	○	○	Chorus Level
	120	○	○	All Sound Off
	121	x	○	Reset All Controllers
123	○	○	All Notes Off	
Program Change	:True	○ *****	○ 1–127	
System Exclusive		x	○	
System Common	:Song Position	x	x	
	:Song Select	x	x	
	:Tune	x	x	
System Real Time	:Clock	○	x	
	:Commands	x *1	x *1	
Aux Messages	:LOCAL ON/OFF	x	x	
	:Active sense	x	○	
	:Reset	x	○	
Notes: *1 When the accompaniment is started, an FAH message is transmitted. When the accompaniment is stopped, an FCH message is transmitted.				

- Mode 1: OMNI ON, POLY
- Mode 2: OMNI ON, MONO

- Mode 3: OMNI OFF, POLY
- Mode 4: OMNI OFF, MONO

- : YES
- x: NO

