

Digital Piano
WK-520
Owner's Manual

NUX

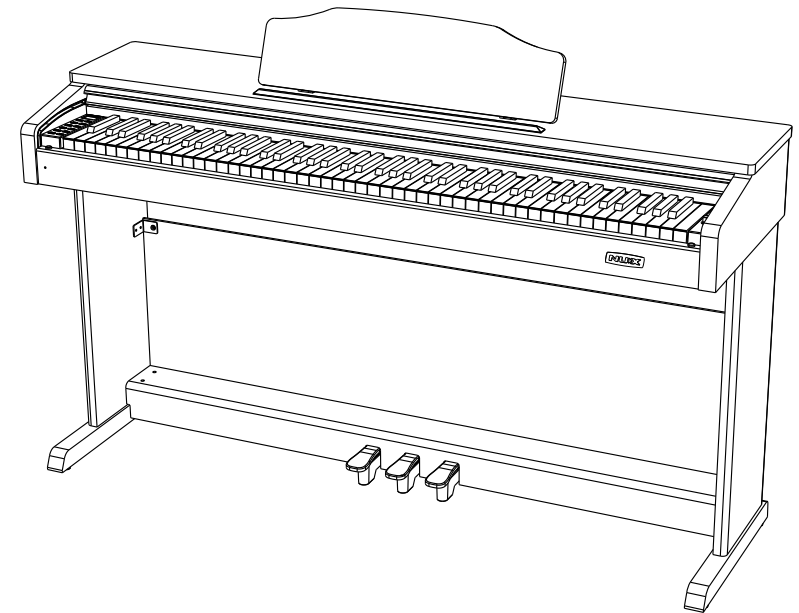

Cherub Technology Co.,Ltd.

Add: Room507, Block 1, Nanhai E-Cool, No. 6 Xinghua Road, Shekou, Nanshan District,
Shenzhen City, Guangdong Province, China, 518067

Tel: +86 755 2686 9866 Fax: +86 755 2686 9366 E-mail: info@cherubtechnology.com



www.nuxefx.com

Cherub Technology Co.,Ltd.

Copyright 2018 Cherub Technology Co., Ltd. All rights reserved.

Strictly prohibit reproducing or spreading any part of this publication in any manner without the authorization of Cherub Technology Co., Ltd.

SAFETY GUIDELINE

Before playing your digital piano, please read the following content. Please store this instruction book in a safe place, for future reference.

WARNING

To avoid serious injury or death because of electric shock, short circuit, fire or other dangers, please obey the following warnings. These warnings include but are not limited to the following situations:

Power/Electric Cable

- * The rated voltage of this device is fixed. The required voltage is printed on the nameplate of this device.
- * Check the plug regularly, and clean off any dirt / debris that accumulates on the electrical plug.
- * This digital piano only matches with the provided power cable and plug.
- * DO NOT put electric cables near heaters, radiators or any other heating devices. DO NOT overstress electrical cables with extreme bending or abrasion which can cause damage and expose wiring. DO NOT position cables under heavy items such as furniture etc. DO NOT position electrical cables where they can be run over with wheels or in walkways where they can be tripped over.

Do Not Open / Dismantle

- * DO NOT attempt to open / dismantle inner components or customize the device in any way. This device is not designed for user maintenance other than cleaning of external components. If you experience any problems, please turn off and unplug the device, and then consult a qualified NUX service technician to examine and repair the device.

Humidity

- * DO NOT place this device where it will be exposed to water, (rain, mist, water sprinklers, water entertainment equipment etc.) and DO NOT place liquid containers of any kind on or where they can be spilled on the device. If any liquids splash or are spilled onto the device, immediately UNPLUG from AC socket immediately. Then ask qualified NUX service staffs to examine and repair the device.
- * DO NOT plug device with wet hands.

Fire And Flamables

- * To prevent risk of FIRE, DO NOT place open flames, such as candles, or flame-ables of any kind on or near the instrument.

Unusual Behaviour Or Wear Of Device

- * Be aware of worn or damaged power cables, sudden unusual loss of sound during playing, and the smell and or visual signs of smoke or fire. In this event, immediately disconnect the device from AC socket. Consult a qualified NUX service technician to examine and repair the device.

Attention

- * To prevent bodily injury or damage to device and property, please obey the following SAFETY GUIDELINES BELOW. These instruments include but are not limited to following situations.

Power / Electrical Cables

- * When pulling out plug from AC socket, please grab the PLUG instead of power cable which can cause damage to the CABLE !!!

- * When the instrument is not in use for long periods of time or during a lighting storm, please unplug the device from any AC socket.
- * Do not connect the instrument to a power source with multiple connectors, which will lower the sound quality, and overheat your AC socket.

Assembly & Use

- * Please carefully read the attachment explaining the assemble process. Failure to assemble the instrument in the proper order will damage the instrument and potential cause danger to the user.
- * Please connect the external equipment while the digital piano is off.

Mount Position

- * To avoid deformation of control panel and/or damage to inner components, only operate this device in clean environments which are free of excessive dirt, vibration, and extreme cold or heat (such as, direct sunlight or near heaters or left inside a vehicle whereas sun and cold can be an issue.)
- * Please DO NOT use this device near a television, radio, stereo, cell phone or other electronic devices which can cause mutual interference / unwanted noise.
- * Please DO NOT place this device on unstable or uneven surfaces, which can allow the unit to fall over.
- * Before moving the device, please remove all electrical cables from the AC socket.
- * When you set-up this device, only use an AC socket that is in good condition, and is easily accessible. The device should only be connected to an AC socket which provides protective grounding access. If you detect or experience any difficulties, immediately unplug the device from the AC socket. Keep in mind that, even when the power is turned OFF, there is still a small amount of electrical current flowing though the device. If you plan to not use the device for a long period of time, disconnect the device from its AC power source.

- * This product features a MASTER POWER SWITCH on the RIGHT SIDE of the keyboard. When the POWER BUTTON is PRESSED-IN, the power is switched ON. When the POWER BUTTON is in the UP-POSITION, it is switched OFF.

The illustrations in this hand book are for overview and orientation purposes only, and may differ slightly from the instrument you purchase.

Catalogue

Quick Installation Guide	07
Control Panel	09
Before You Start	11
Power On	11
Volume Control	11
Connecting Headset	11
Owner's Manual	12
Sound Control	12
Demo Songs	12
Metronome	13
Accompaniment control	13
Record Function	16
Play	16
Dual Keyboard	16
Touch	17
Transposing	18
Dual Voice	18
Reverb	19
Chorus	19

Using the APP	20
USB MIDI Function	20
Audio Connection	21
Specifications	22
Timbre	23
Rhythm List	34
Demo List	38
Trouble Shooting	40

Quick Installation Guide

Thank you for choosing NUX Digital Piano. Whether you are a student, piano hobbyist or a professional musician, you'll enjoy this digital piano's impressive sound and fashion design. It's perfect for practice, recording or live performance. It also features a MIDI interface, which will satisfy all of your recording or entertainment demands. And it features a grand hammer dynamic keyboard, making you express yourself easily.

For further information about this new digital piano, we suggest you should read this hand book carefully in order to make full use of its advanced and convenient functions. Meanwhile, we also suggest you should keep this hand book well for reference in the future.

If you like your NUX digital piano, please recommend NUX to your friends.

----- Assembly Component List -----

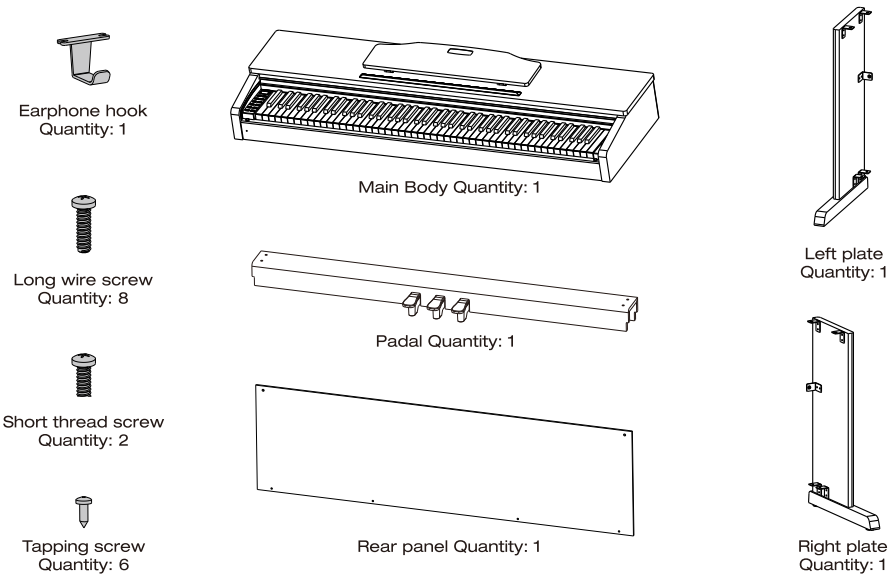

1. Mount LEFT side board, RIGHT side-board and pedal.

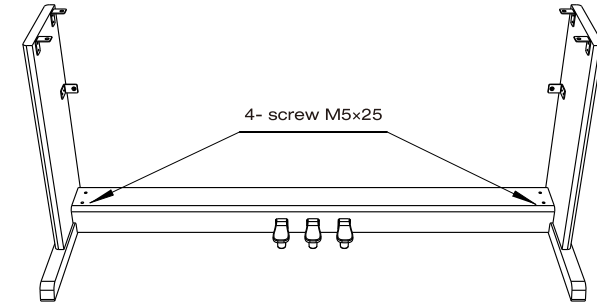

2. Install REAR panel.

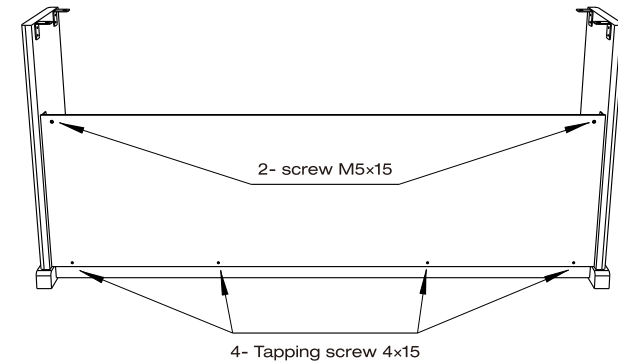

3. Mount main body and Earphone hook.

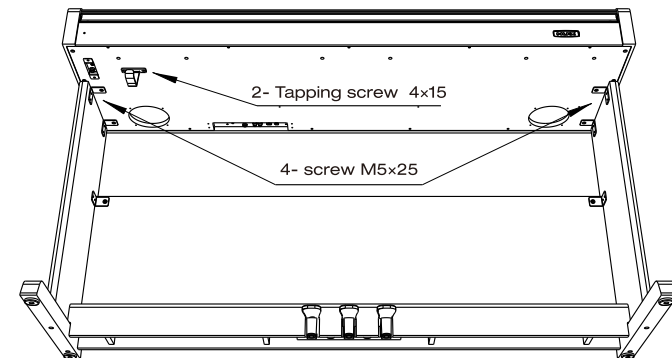

Control Panel

Left Control Panel

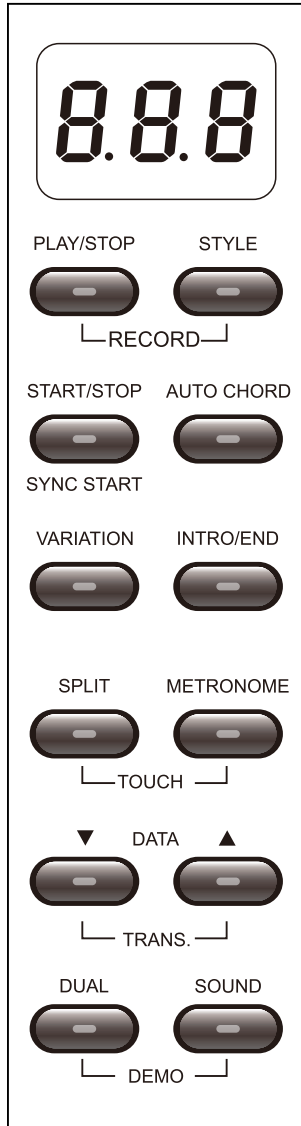

Right Control Panel

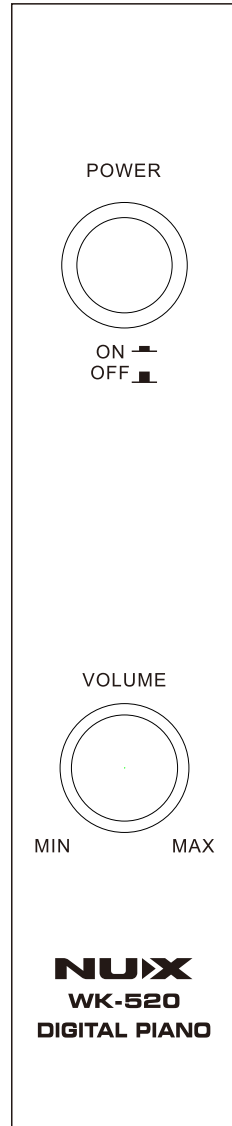

Rear Panel Interface



- **Power interface:** Connect the power adapter (DC12V, 2000mA, positive outside and negative inside)
- **USB MIDI Interface:** Connect the digital piano to a computer, use as MIDI keyboard.
- **Audio input interface:** LEFT and RIGHT channel input, Connect other instruments to the digital piano internal sound amplification system.
- **Audio output interface:** LEFT and RIGHT channel output, Connect digital piano to external sound amplification system.
- **Headphone jack:** RIGHT-SIDE / BELOW the keyboard, Standard 6.35mm and 3.5mm stereo headphone interface, Connecting the mouth can silence the speaker system inside the digital piano.
- **Pedal interface:** The pedal connection line is inserted into the mouth, and the pedal can.

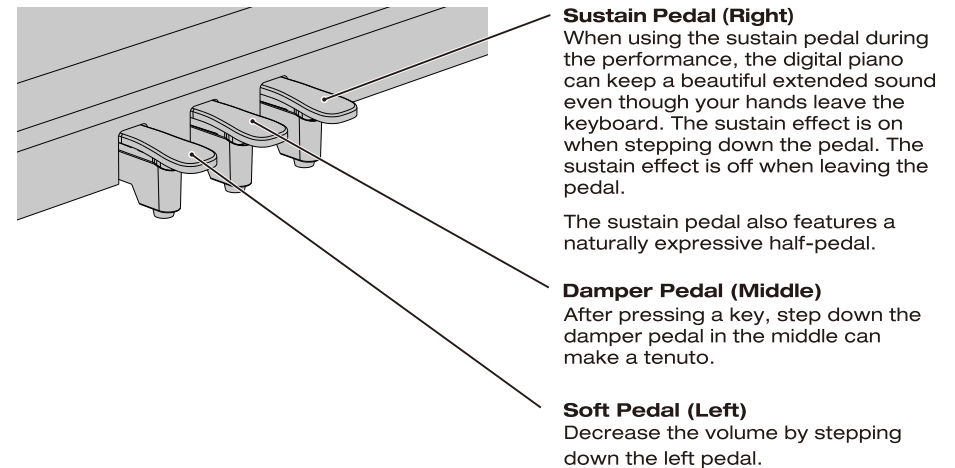

Power

Connect the AC plug to a proper socket and then press the [**POWER**] button on the right side of the keyboard to turn on the power. The default sound is grand piano.



Volume Control

Turn the [**VOLUME**] KNOB on the control panel to set the volume. Turn the KNOB clockwise to raise volume. Turn the KNOB anti-clockwise to reduce volume.

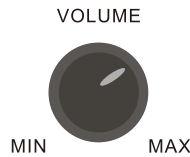

Warning: Too loud sound, especially when you wear the headphone, will do damage to hearing.

Connecting Headset

In addition to the built-in speaker system, you can also connect two standard stereo headphones (6.35mm or 3.5mm).

Headphone jack is located on the LEFT SIDE under the keyboard. The built-in speaker system is disabled when using the headphone jack. Adjust the headphone volume by turning the [**Master Volume**] knob.

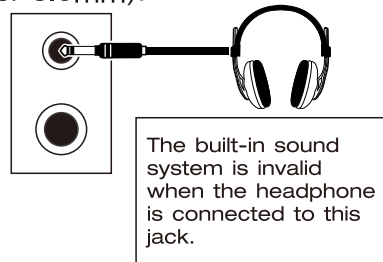

Sound Control

1. PRESS the [**SOUND**] button light, enter the sound selection state.
2. PRESS the [▲] and [▼] button (within 5 seconds) to select any tone.
3. The default tone is grand piano tone.

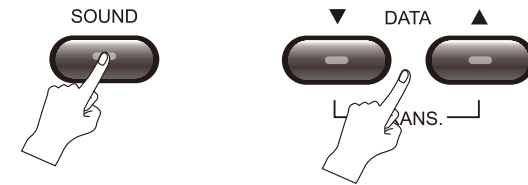

Demo Songs

1. Press [**DUAL**] and [**SOUND**] two buttons together to start to play.
2. During play status, Press [▲] or [▼] button to select corresponding song.
3. Press [**DUAL**] and [**SOUND**] two buttons together again to stop playing.



Metronome

Regulating speed:

1. PRESS [**METRONOME**] button on control panel to start metronome function and the indicator light will flash. LED will display the beat velocity. The default velocity is 120 beats/min.
2. Press [▲] or [▼] button to adjust beat velocity from 20 to 280.



Select beats:

1. Press / hold [**METRONOME**] button. Enter the beat type selection.
2. This digital piano has six different beat selections, press /hold [**METRONOME**] button and the indicator light turns on. Press [▲] or [▼] button to adjust beat.
3. Press [**METRONOME**] button again to exit metronome setting.



Accompaniment Control

Choose rhythm:

1. Press [**STYLE**] button, enter the state of rhythm regulation.
2. Press [▲] or [▼] button to change the rhythm.
3. Press other buttons to exit rhythm adjustment state.



Accompaniment start:

1. Press [**START/STOP**] button , the button light will flash. Accompaniment auto-start.
2. Press [**START/STOP**] button again, the accompaniment stopped.

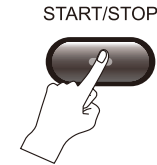

1. Press [**START/STOP**] button , the accompaniment will start immediately.
2. Press [**START/STOP**] button again , the accompaniment will stop.



1. Press [**METRONOME**] button, the button lights are lit.

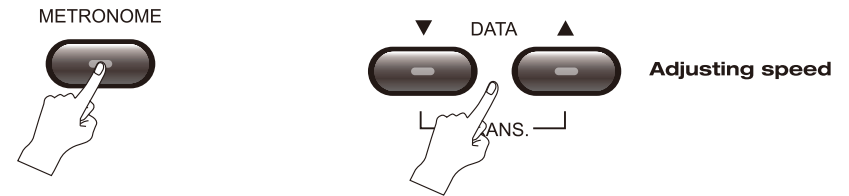

Automatic Chord:

1. Press [**AUTO CHORD**] button , the button lights are lit. Play the left half of the keyboard. Single finger or multi finger will be identified. At the same time, the corresponding chords are automatically matched, enter the synchronous start state.
2. Press [**AUTO CHORD**] button again , the automatic chord will stop.



Prelude/coda:

1. Press [**INTRO/END**] button to start prelude and enter the main musical a status automatically.
2. When the automatic accompaniment is playing, press the [**INTRO/END**] button and the automatic accompaniment will stop automatically after playing a piece of coda.



Variation:

1. After entering the main play, press the [**VARIATION**] button and start to play the variations.
2. Press the [**VARIATION**] button again to play the main.



Insert:

1. When the automatic accompaniment is playing, press the [**INTRO/END**] button and the [**STYLE**] button, the accompaniment will be automatically inserted into a rhythm to return to the normal rhythm.



Record Function

1. Press [**PLAY/STOP**] and [**STYLE**] keys simultaneously.
2. The button light indicates the beginning of the recording.
3. Simultaneously open the beat and metronome automatically, if not need to be manually closed.
4. Press [**PLAY/STOP**] button and the recording ends.

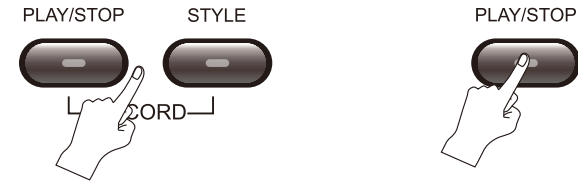

Play

1. After the recording, press the [**PLAY/STOP**] button to begin playing the recording.
2. Press the [**PLAY/STOP**] button to end the playback.



Dual Keyboard

This function will divide the keyboard into 2 individual playing zones.

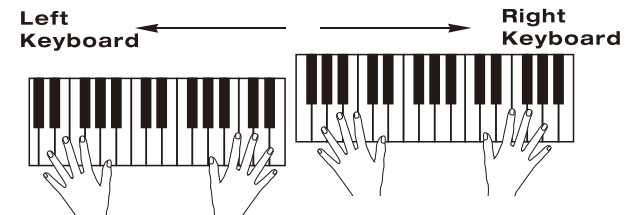

Press [**SPLIT**] button, (button lights), to enter dual keyboard mode.

The default keyboard separation point is f4 (no. 45).

Split point:

1. Press [**SPLIT**] button, the button lamp flicker, enter the setting state.
2. Press any key to set the separation point ,the led screen displays the serial number of the key, after 5 seconds, automatically confirm the new keyboard separation point.

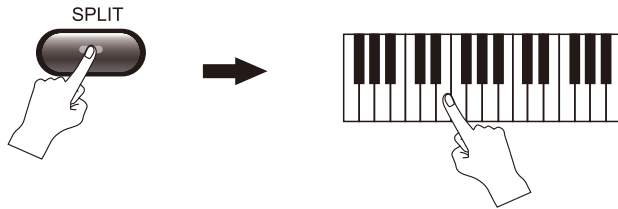

Set the tone:

1. The tone of the left keyboard area must be set before entering the dual keyboard state.
2. In the right keyboard area, the tone of the area is in the double keyboard state, press the [**SOUND**] button.

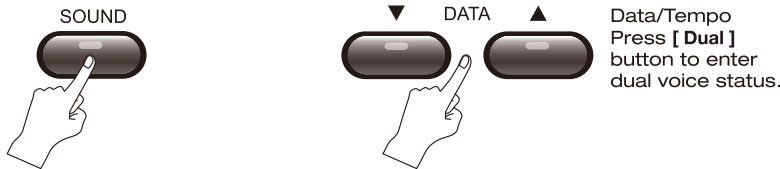

Touch

1. Press the [**SPLIT**] and the [**METRONOME**] buttons to set the strength, the default standard on startup.
2. Press [▲] or [▼] button, select 4 kinds of dynamics: close / light / standard /heavy. Led display screen shows 00/01/02/03, respectively.
3. Automatically confirm the selection after 5 seconds.

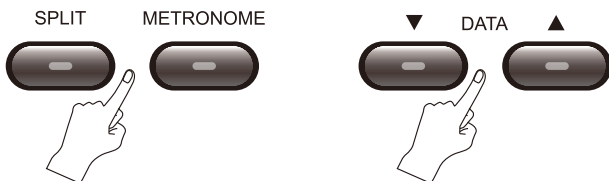

Transposing

1. Simultaneously press both [▲] and [▼] buttons, to enter the shift status. Led display will display "00".
2. Press [▲] or [▼] button, to select the shift range. Led display (-12~ 12).
3. Press [▲] and [▼] button to cancel the shift. Buttons will light up respective to which direction you are transposing, up or down.

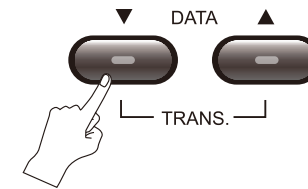

Dual Voice

Choose sound:

Press [**SOUND**] button, and then press [▲] or [▼] button to switch the second tone. The 1st tone needs to be set before entering the dual tone mode.

Tone balance:

Press [**SOUND**] button, and then press [▲] or [▼] button to adjust the balance of the 2nd tone.

The led screen shows the percentage of the 2nd tone color.



Reverb

1. At the same time, step on the left and middle two pedals, and press the 2nd white key to unlock the reverberation function.
LED display "r.o n".
2. At the same time, step on the left and middle two pedals and close the reverberation function by pressing the 1st white key.
LED display "r.o f".

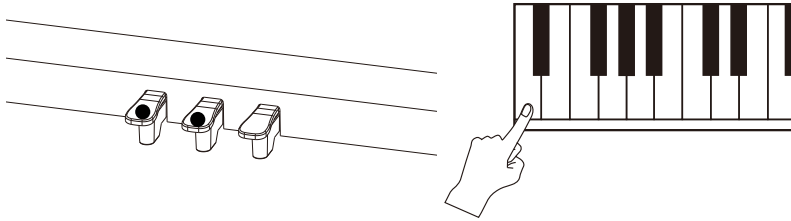

Chorus

1. At the same time, step on the left and middle two pedals, and start the chorus function by pressing the fourth white key.
The LED display is "c.o n".
2. At the same time, step on the left and middle two pedals and close the chorus function by pressing on the 3rd white key.
LEDdisplay "c.o f".

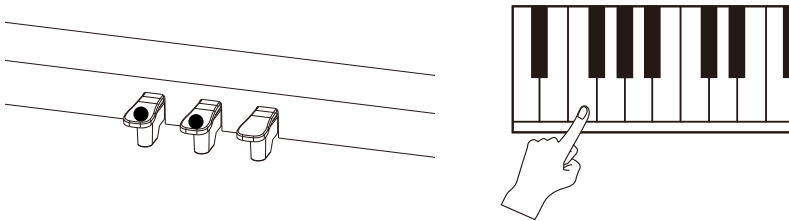

Using the APP

WK-520 is compatible with the APP "Piano Mate" for iOS and Android. "Piano Mate" has a collection of onboard sheet music, and makes practicing and teaching more convenient. Scan the QR code and download the app corresponding to the mobile device you are using:



After installing the "Piano Mate" on your mobile device, you can register and open the sheet music. Then turn on the Bluetooth on the sheet music page, and select "NUX PIANO *****" for pairing connection.

Note: The Bluetooth connection between the digital piano and the "Piano Mate" APP does not require the Bluetooth Audio function. When the digital piano is powered on, the APP will automatically recognize it.

USB MIDI Function

Use the USB MIDI interface of the digital piano rear panel to connect to the computer, which can directly make the MIDI function.

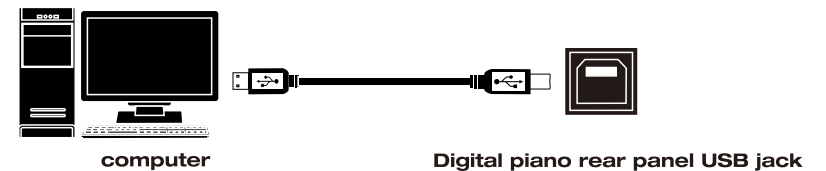

Audio Connection

Audio Input: Connect the musical instrument to the built-in speaker system, regarding the digital piano as speaker.

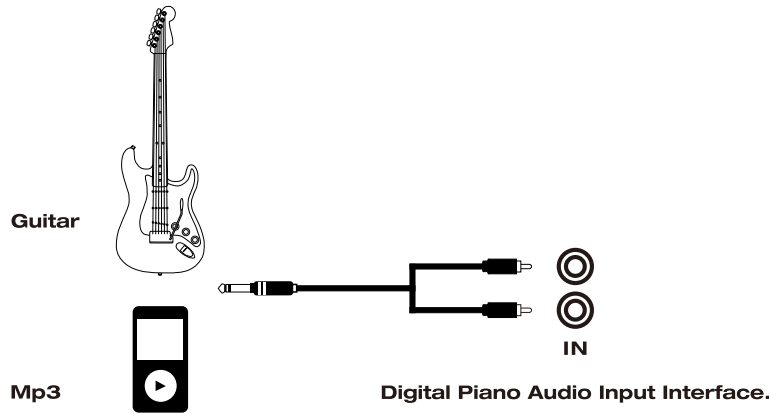

Audio Output: Regarding this digital piano and sound source, connect it to the external speaker system.

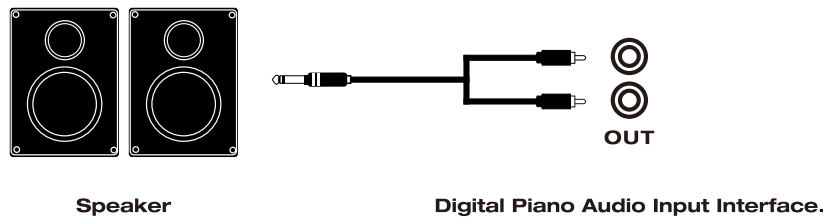

Specifications

- **Exterior:** Standard Upright.
- **Surface:** Dark Wooden PVC.
- **Keyboard:** 88 keys scaled hammer action keyboard with four dynamic curves.
- **Sound Source:** European Top DSP chip; 5 dynamic levels of stereo piano sampling; Harmonic Series Simulation and Sympathetic Resonance Technology.
- **Max Polyphony:** 189.
- **Sound:** 300.
- **Demo Song:** 52 Demo Songs.
- **Dynamic Curve:** 4 kinds of standard piano dynamic curves (soft, standard, hard, Dynamic on/off).
- **Rhythm Style:** 100.
- **Transposition:** 25 semitones (-12~+12).
- **Octave Shift:** 3 octaves (-8, 0, +8).
- **Metronome:** Velocity 20-280bpm, beat 1-6.
- **Function Option:** Recording Function, Reverb, Chorus, Dual Voice, Dual Keyboard, Teaching Function.
- **Pedal Function:** Soft Pedal (left), Damper Pedal (Middle), Sustain Pedal (Right). The sustain pedal also features a naturally expressive half-pedal.
- **Jack:** USB MIDI Jack, Power Jack, Pedal Jack, Headphone Jack*2, Stereo Line Input Jack, Stereo Line Output Jack.
- **Power:** 24W DC12V 2000mA.
- **Dimensions:** 1372(L)X472(W)X862(H)mm.
- **Weight:** 45Kg.
- **Accessories:** AC Adapter, Owner's Manual.

★ If the product upgrade, to prevail in kind.

Timbre

Number	Instrument
Piano	
1	Acoustic Grand Piano
2	Bright Acoustic Piano
3	Electric Grand Piano
4	Honky-tonk Piano
5	Electric Piano1
6	Electric Piano2
7	Harpsichord
8	Clavichord
Percussion	
9	Celesta
10	Glockenspiel
11	Music box
12	Vibraphone
13	Marimba
14	Xylophone
15	Tubular Bells
16	Dulcimer
Organ	
17	Hammond Organ
18	Percussive Organ
19	Rock Organ
20	Church Organ
21	Reed Organ
22	Accordian
23	Harmonica
24	Tango Accordian

Number	Instrument
Guitar	
25	Acoustic Guitar (nylon)
26	Acoustic Guitar (steel)
27	Electric Guitar (jazz)
28	Electric Guitar (clean)
29	Electric Guitar (muted)
30	Overdriven Guitar
31	Distortion Guitar
32	Guitar Harmonics
Bass	
33	Acoustic Bas
34	Electric Bass (finger)
35	Electric Bass (pick)
36	Fretless Bass
37	Slap Bass 1
38	Slap Bass 2
39	Synth Bass 1
40	Synth Bass 2
String	
41	Violin
42	Viola
43	Cello
44	Contrabass
45	Tremolo Strings
46	Pizzicato Strings
47	Orchestral Harp
48	Timpani
Ensemble	
49	String Ensemble 1

Number	Instrument
50	String Ensemble 2
51	Synth Strings 1
52	Synth Strings 2
53	Choir Aahs
54	Voice Oohs
55	Synth Voice
56	Orchestra Hit
Brass	
57	Trumpet
58	Trombone
59	Tuba
60	Muted Trumpet
61	French Horn
62	Brass Section
63	Synth Brass 1
64	Synth Brass 2
Reed	
65	Soprano Sax
66	Alto Sax
67	Tenor Sax
68	Baritone Sax
69	Oboe
70	English Horn
71	Bassoon
72	Clarinet
Band	
73	Piccolo
74	Flute
75	Recorder

Number	Instrument
76	Pan Flute
77	Bottle Blow
78	Shakuhachi
79	Whistle
80	Ocarina
Electronic	
81	Lead 1 (square)
82	Lead 2 (sawtooth)
83	Lead 3 (calliope lead)
84	Lead 4 (chiff lead)
85	Lead 5 (charang)
86	Lead 6 (voice)
87	Lead 7 (fifths)
88	Lead 8 (bass+lead)
Synthetic sound	
89	Pad 1 (new age)
90	Pad 2 (warm)
91	Pad 3 (polysynth)
92	Pad 4 (choir)
93	Pad 5 (bowed)
94	Pad 6 (metallic)
95	Pad 7 (halo)
96	Pad 8 (sweep)
FX	
97	FX 1 (rain)
98	FX 2 (soundtrack)
99	FX 3 (crystal)
100	FX 4 (atmosphere)
101	FX 5 (brightness)

Number	Instrument
102	FX 6 (goblins)
103	FX 7 (echoes)
104	FX 8 (sci-fi)
Nation	
105	Sitar
106	Banjo
107	Shamisen
108	Koto
109	Kalimba
110	Bagpipe
111	Fiddle
112	Shanai
Hit	
113	Tinkle Bell
114	Agogo
115	Steel Drums
116	Woodblock
117	Taiko Drum
118	Melodic Tom
119	Synth Drum
120	Reverse Cymbal
Sound	
121	Guitar Fret Noise
122	Breath Noise
123	Seashore
124	Bird Tweet
125	Telephone Ring
126	Helicopter
127	Applause
128	Gunshot

Sort	Number	MIDI PG#	MIDI BANK	Instrument
Piano 2	129	1	8	Piano w
	130	1	16	Piano d
	131	3	1	Upright Piano 2
	132	3	2	Upright Piano 3
	133	4	1	HonkyTonk w
	134	5	1	Rhodes2
	135	5	8	Detuned EP1
	136	5	24	60s E.Piano
	137	6	3	E.Piano 2
	138	6	8	Detuned EP2
	139	6	16	E.Piano 2v
	140	7	1	Harpsichord 2
	141	7	8	Coupled Hps
	142	7	24	Harpsi.o
Percussion 2	143	8	1	Clavichord 2
	144	9	8	Celesta 2
	145	11	8	Music Box 2
	146	12	8	Vibraphone 2
	147	14	8	Xylophone 2
	148	15	8	Tubular-bell 2
	149	16	1	Santur
Organ 2	150	17	1	Organ 101
	151	17	8	Detuned Or1
	152	17	32	Organ 1
	153	18	1	Organ 201
	154	18	8	Detuned Or2
	155	18	32	Organ 2
	156	19	1	Rock Organ 2
	157	20	8	Church Organ 2
	158	21	1	Reed Organ 2

Sort	Number	MIDI PG#	MIDI BANK	Instrument
Organ 2	159	22	1	Accordion 2
	160	22	8	Accordion 3
	161	23	1	Harmonica 2
	162	24	1	Bandoneon
Guitar 2	163	25	1	Nylon Gt 2
	164	25	2	Nylon Gt 3
	165	25	3	Nylon Gt 4
	166	25	8	Ukulele
	167	26	8	12-str.Gt
	168	26	16	Mandolin
	169	27	8	Hawaiian Gt
	170	28	1	Clean Gt 2
	171	28	2	Clean Gt 3
	172	28	8	Chorus Gt
	173	29	1	Muted Gt 2
	174	29	2	Muted Gt 3
	175	29	8	Funk Gt 1
	176	29	16	Funk Gt 2
	177	31	1	Dist. Gt 2
	178	31	2	Dist. Gt 3
179	31	8	Feedback Gt	
180	32	8	Gt.Feedback	
Bass&Elc	181	33	1	Synth 1
	182	33	2	Synth 2
	183	35	2	Synth 3
	184	36	2	Synth 4
	185	36	3	Synth 5
	186	39	2	Synth 6
	187	39	4	Synth 7
	188	39	6	Synth 8

Sort	Number	MIDI PG#	MIDI BANK	Instrument
Bass&Elc	189	36	1	Synth 9
	190	35	1	Synth 10
	191	40	6	Synth 11
	192	40	7	Synth 12
	193	40	8	Synth 13
	194	39	8	Synth 14
String 2	195	41	1	Violin 2
	196	42	1	Viola 2
	197	43	1	Cello 2
	198	44	1	Contrabass 2
	199	47	1	Harp 2
	200	49	8	Strings
Ensemble 2	201	51	8	Syn Strings
	202	52	1	JUNO Strings
	203	53	1	Choir Aahs2
	204	54	1	Voice doo 2
	205	55	8	Synth Voice2
Copper pipe 2	206	57	1	Trumpet 2
	207	58	1	Trombone 2
	208	58	2	Trombone 3
	209	59	1	Tuba 2
	210	60	1	MuteTrumpet 2
	211	61	1	French Horn 2
	212	61	2	French Horn 3
	213	62	1	Brass 2
	214	63	8	Synth Brass 3
	215	63	16	Analog Brs1
	216	64	8	Synth Brass 4
	217	64	16	Analog Brs2

Sort	Number	MIDI PG#	MIDI BANK	Instrument
Copper pipe 2	218	65	1	Soprano Sax 2
	219	65	2	Soprano Sax 3
	220	66	1	Alto Sax 2
	221	67	1	Tenor Sax 2
	222	67	8	Tenor Sax 3
	223	68	1	BaritoneSax 2
	224	69	1	Oboe 2
	225	70	1	EnglishHorn 2
	226	71	1	Bassoon 2
	227	72	1	Clarinet 2
Band 2	228	73	1	Piccolo 2
	229	74	1	Flute 2
	230	75	1	Recorder 2
	231	76	1	Pan Flute 2
	232	77	1	Bottle Blow 2
	233	78	1	Shakuhachi 2
Lead 2	234	81	1	Square 2
	235	81	8	Sine Wave
	236	82	1	Saw 2
	237	82	8	Doctor Solo
	238	86	8	Vox Lead
Synthetic sound 2	239	92	8	Space Voice
	240	99	1	Syn Mallet
	241	101	8	Brightness 2
	242	102	8	Goblin 2
	243	103	1	Echo Bell
Nation 2	244	105	1	Sitar 2
Hit 2	245	116	8	Castanets
	246	117	8	Concert BD
	247	118	8	Melodic Tom 2

Sort	Number	MIDI PG#	MIDI BANK	Instrument
Hit 2	248	119	8	808 TomElectric
	249	119	9	Percussion
	250	121	2	String Slap
	251	122	1	Fl.KeyClick
	252	123	1	Rain
	253	123	2	Thunder
	254	123	3	Wind
	255	123	4	Stream
	256	123	5	Bubble
	257	124	1	Dog
	258	124	2	HorseGallop
	259	124	3	Bird 2
	260	125	1	Telephone 2
	261	125	2	Creaking
	262	125	3	Door
	263	125	4	Scratch
	264	125	5	Wind Chime
	265	126	1	Car-Engine
	266	126	4	Car-Crash
	267	126	5	Siren
	268	126	6	Train
	269	126	7	Jetplane
	270	126	8	Starship
	271	127	1	Laughing
	272	127	2	Screaming
	273	127	4	Heart Beat
	274	127	5	Footsteps
	275	128	1	Machine Gun
276	128	3	Explosion	

Sort	Number	MIDI PG#	MIDI BANK	Instrument
Percussion 2	277	9	100	Luo 1
	278	10	100	Luo 2
	279	15	100	Bian Zhong
	280	16	100	Yang Qin
Nation 3	281	25	100	Liu Qin
	282	26	100	Pi Pa
	283	27	100	Zhong Ruan
	284	107	100	San Xian
	285	108	100	Gu Zheng
	286	108	101	Gu Qin
Nation 4	287	22	100	Shen 1
	288	65	100	Na Zi 1
	289	70	100	Guan Zi 1
	290	72	100	Ba Wu
Nation 5	291	73	100	Di Zi 1
	292	75	100	Hu Lu Si
	293	76	100	Pai Xiao
	294	78	100	Xiao
	295	80	100	Xun
Nation 6	296	41	100	Gao Hu
	297	42	100	Er Hu
	298	43	101	Ma Tou Qin
	299	82	100	Jing Hu
	300	49	100	Hu Ensemble 1

Rhythm List

Number	Instrument
8BEAT	
1	8 BEAT 1
2	8 BEAT 2
3	8 BEAT 3
4	8 BEAT 4
5	8 BEAT 5
6	8 BEAT 6
7	8 BEAT 7
8	8 BEAT 8
9	8 BEAT ROCK 1
10	8 BEAT ROCK 2
11	8 BEAT ROCK 3
16BEAT	
12	16 BEAT 1
13	16 BEAT 2
14	16 BEAT 3
15	16 BEAT 4
16	16 BEAT 5
17	16 BEAT 6
18	16 BEAT 7
19	16 BEAT 8
20	16 BEAT 9
21	16 BEAT 10
DANCE	
22	DANCE 1
23	DANCE 2
24	DANCE 3
25	DANCE 4
26	DANCE 5

Number	Instrument
27	DANCE 6
28	DANCE 7
29	DANCE 8
30	DANCE 9
31	DANCE 10
JAZZ	
32	FOX TROT 1
33	FOX TROT 2
34	FOX TROT 3
35	FOX TROT 4
36	FOX TROT 5
37	FOX TROT 6
38	FOX TROT 7
39	FOX TROT 8
40	FOX TROT 9
41	FOX TROT 10
LATIN	
42	LATIN 1
43	LATIN 2
44	LATIN 3
45	LATIN 4
46	LATIN 5
47	TANGO
48	RAGGAE
49	MAMBO
TRADITIONAL	
50	MARCH 6.8
51	MARCH 4.4
52	MARCH 1
53	MARCH 2
54	MUSETTE

Number	Instrument
55	POLKA
56	TRADITIONAL WALTZ
57	VIENER WALTZ
58	WALTZ 1
59	WALTZ 2
POP	
60	POP 1
61	POP 2
62	POP 3
63	POP 4
64	POP 5
65	POP 6
66	POP 7
67	POP 8
68	POP 9
69	BALLAD
ROCK	
70	ROCK 1
71	ROCK 2
72	ROCK 3
73	ROCK 4
74	ROCK 5
75	ROCK 6
76	ROCK 7
77	ROCK 8
78	ROCK 9
79	ROCK 10
SWING	
80	SWING1
81	SWING2
82	SWING3

Number	Instrument
83	SWING4
84	SWING5
85	SWING6
86	SWING7
87	SWING8
88	SWING9
89	SWING10
COUNTRY	
90	TWO STEP
91	COUNTRY 1
92	COUNTRY 2
93	COUNTRY 3
94	COUNTRY 4
ORIENTAL	
95	DANGDUT
96	ASIA POP
97	KOREAN
98	MONGOLIAN
99	ARABIAN
100	KRONCONG

Demo List

Number	Instrument
1	TURKISH MARCH
2	THE MAIDEN'S PRAYER
3	D MAJOR TANGO
4	ARABESQUE
5	WALTZ IN D FLAT,OP.64 NO.1
6	CHOPIN:IMPROMPTU OP.66
7	WHEN A CHILD IS BORN
8	SOMEWHERE OUT THERE
9	SALUT D' AMOUR
10	MUSICBOX
11	WHEELS ON THE BUS
12	CARRY ME BACK TO LOD VIGINNY
13	PERSIAN MARKET
14	GWINE TO RUN ALL NIGHT
15	TCHAIKOVSKY:WALTZ IN E FLAT MAJOR
16	KENNYG SONGBIRD
17	SUPER MARIE UNDERWATER PASS
18	DAISY PUPPY
19	SOMALILAND
20	PHANTOM OF THE OPERA
21	JUNE SMBA
22	SIX LITTLE DUCKS
23	LONDON HORN
24	MACARENA
25	DETECTIVE CONAN
26	MODERN GRAY
27	JASMINE FLOWER
28	LEMON TREE
29	SOMETHING IN THE AIR

Number	Instrument
30	SILENT NIGHT
31	ENDLESS GARDEN
32	AVE MAIRA
33	TOP OF THE WORLD
34	JOYFUL
35	SUMMER PALACE
36	LAST ROSE OF SUMMER
37	SUMMER
38	STRINGS NOCTURNE
39	COUNTRY
40	COUPER:IN THE LITTLE WINDMILLS
41	THE SIDEWAY
42	LITTLE STAR
43	WALTZ OF STARLIGHT
44	ATLANTIS
45	SCHUBERT:HEIPENPOSLEIN
46	I DO IT FOR YOU
47	THE STAGE COACH
48	BLUE LUNCH
49	KISS THE RAIN
50	RHYTHM OF THE RAIN
51	YUZHAO
52	BLUEMOON

Trouble Shooting

Trouble	Possible Reason/Solution
The digital piano will puff when it is switched on.	Don't worry.This is normal.
Pressing key makes no sound after the power is on.	Determine whether the master volume button is set properly or confirm whether the headphone jack is linked to other devices, which will automatically cut off the built-in speaker system.
Notes have different quality under the same sound.	This is normal because different sound sampling ranges make different sound quality.
In pedal sustain function, some sound sustains longer than others.	Determine whether the master volume button is set properly.
The sound is too small.	This is normal.It is related to the original setting.
Some MIDI Data can not be transmitted correctly (Even when the MIDI cable is linked correctly)	The call phone will jam when it is nearby. The cell phone should be turned off or used away from the digital piano to avoid jamming.
The speaker will make noise when cell phone is nearby.	You may have the double keyboard function or transposition function turned on.Turning off double keyboard or resetting the transposition to zero will resolve this issue.
The pitch doesn't appear to match with its corresponding key.	You may have the double keyboard function turned on, and the split point is set to the highest pitch. Turning off double keyboard function and setting the split point to its original status will resolve this issue.
The sound can not be changed while playing.The pitch doesn't match with key actual place.	You may have the double keyboard function turned on, and the split point is set to the highest pitch. Turning off double keyboard function and setting the split point to its original status will resolve this issue.
The demo song distorts or interrupts.	Playing at maximum volume for long periods will activate the circuit board self-protection system to prevent overheating. Turn down the volume or turn off power for a while can solve the problem.
There are two sounds at the same time while playing.	You may have turned on the dual voice function. Turning off the dual voice function will resolve this issue.
The tone's pitch is wrong.	Set scale and tones or set temperament parameter values to zero.
NO automatic accompaniment chord.	Determine whether accompaniment volume or chord function is turned on.

Trouble	Possible Reason/Solution
Dynamics are different from before.	This digital piano has 4 dynamics, light / standard, heavy / off. You may have chosen different dynamics. You can choose the dynamics again according to your demand or reset it.