

Owner's Manual

***DIGITAL
DRUM***

INFORMATION FOR YOUR SAFETY!

PRECAUTIONS

THE FCC REGULATION WARNING (For USA)

This equipment has been tested and found to comply with the limits for a Class B digital device, pursuant to Part 15 of the FCC Rules.

These limits are designed to provide reasonable protection against harmful interference in a residential installation. This equipment generates, uses, and can radiate radio frequency energy and, if not installed and used in accordance with the instructions, may cause harmful interference to radio communications. However, there is no guarantee that interference will not occur in a particular installation. If this equipment does cause harmful interference to radio or television reception, which can be determined by turning the equipment off and on, the user is encouraged to try to correct the interference by one or more of the following measures:

Connections

Before connecting the instrument to other devices, turn off the power to all units. This will help prevent malfunction and/or damage to other devices.

Location

Do not expose the instrument to the following conditions to avoid deformation, discoloration, or more serious damage:

Direct sunlight
Extreme temperature or humidity
Excessive dusty or dirty location
Strong vibrations or shocks
Close to magnetic fields

Interference with other electrical devices

Radios and televisions placed nearby may experience reception interference. Operate this unit at a suitable distance from radios and televisions.

Cleaning

Clean only with a soft, dry cloth.
Do not use paint thinners, solvents, cleaning fluids, or chemical-impregnated wiping cloths.

PLEASE READ CAREFULLY BEFORE PROCEEDING

Please keep this manual in a safe place for future reference.

Power Supply

Please connect the designated AC adaptor to an AC outlet of the correct voltage.

Do not connect it to an AC outlet of voltage other than that for which your instrument is intended.

Unplug the AC power adaptor when not using the instrument, or during electrical storms.

- Reorient or relocate the receiving antenna.
- Increase the separation between the equipment and receiver.
- Connect the equipment into an outlet on a circuit different from that to which the receiver is connected.
- Consult the dealer or an experienced radio/TV technician for help.

Unauthorized changes or modification to this system can void the user's authority to operate this equipment.

Handling

Do not apply excessive force to the switches or controls.

Do not let paper, metallic, or other objects into the instrument. If this happens, remove the electric plug from the outlet. Then have the instrument inspected by qualified service personnel.

Disconnect all cables before moving the instrument.

CAUTION

The normal function of the product may be disturbed by Strong Electro Magnetic Interference. If so, simply reset the product to resume normal operation by following the owner's manual. In case the function could not resume, please use the product in other location.

Panel Controls	5
- Top Panel	5
- Rear Panel	6
Operation	7
- Select a Drum Kit	7
- Set Pad Voice	7
- Set pad volume	7
- Set pad pan	7
- Set pad midi note	8
- Save Kit	8
- Play Song	8
- Main Volume	8
- Accompaniment Volume	9
- Drum Off	9
- Tempo	9
- Metronome	9
- Hand Percussion	9
- Demo	10
- Reverb	10
- Record	10
- Playback	10
Input and Output	11
- Pedals	11
- Phones output	11
- USB jack	11
- AUX IN input	11
Voice list	12
Kits list	13
Song list	14
MIDI implementation chart	15
Specifications	16

Setting up

Power Supply

Your digital drum will run on either batteries or power adaptor. Follow the instructions below according to the power source you intend to use.

Using an AC- Adaptor

Connect the power adaptor to the DC IN jack located on the rear panel of the unit, and plug the AC power adaptor into an AC power outlet.

Do not use adaptors other than the one specified. The technical specification of the adaptor is DC 12V output, center positive type.

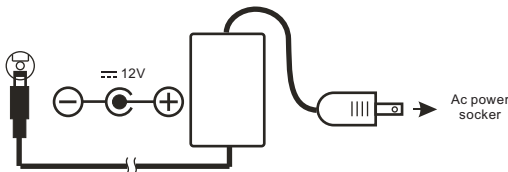

Notes

- Power will be automatically drawn from the AC adaptor if an optional AC adaptor is connected while batteries are installed in the instrument.

Caution

- It is recommended that you replace worn batteries as soon as possible. When battery voltage drops, the display will dim and / or the sound will become distorted, when this occurs, replace the batteries with a complete set of six new batteries of the same type.
- Never mix old and new batteries, different types of batteries (alkaline, magnesium, etc.), Batteries by different makers, or batteries from the same maker but of different types. Misuse may cause the instrument to become hot, result in fire, or battery leakage.

Also, to prevent damage due to battery leakage, remove all the batteries from the instrument when it is not to be used for an extended period of time. Batteries left in an unused instrument will also loose their power overtime.

Using Batteries

- 1 Open the battery compartment cover on the underside of the unit.

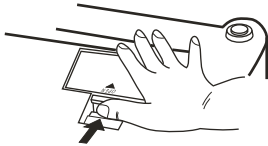

- 2 Insert six "C" size, R14, SUM-2 or equivalent batteries. When inserting the batteries, be care to follow the polarity markings in the illustration.

Note: we suggest to use the alkaline batteries.

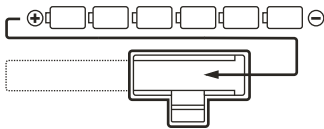

- 3 Close the battery compartment securely.

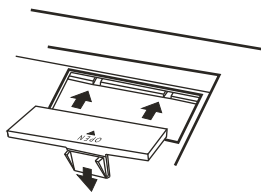

Auto Power Off

In order to save energy, we have designed the "Automatic Shutdown" function. With this function, this product will shutdown automatically when you have left it idle for more than 30 minutes. If you don't need this function, just press and hold the [START/STOP] button then turn the drum on.

Using Headphones

An optional set of stereo headphones can be connected to the PHONES/OUTPUT jack located on the rear panel. when a pair of headphones is connected to the jack, the internal speakers of the unit will switch off automatically, perfect for private practice or late night playing. if you want to use an external sound system, the headphone jack can also be used to connect the digital drum to a stereo system of mixing console.

Turn off the power on all equipment before making any connections.

The headphone is optional.

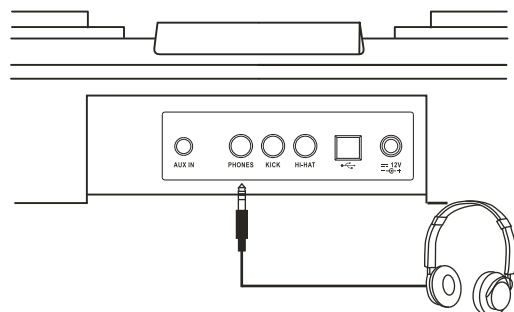

Top panel

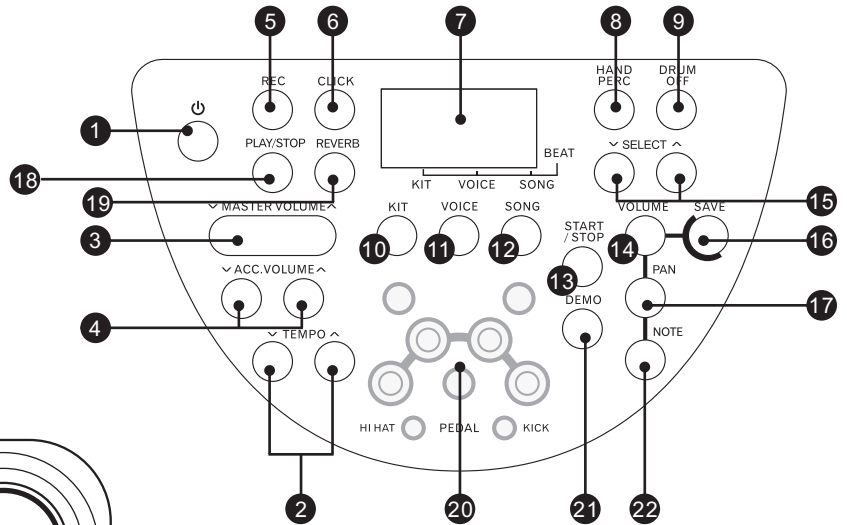
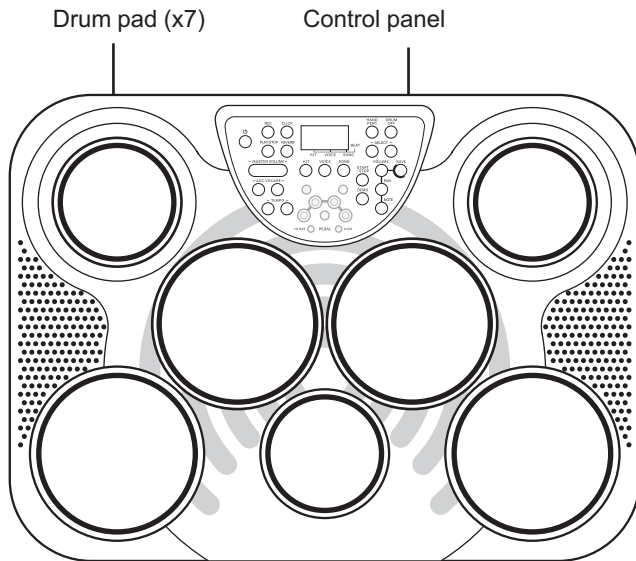

1. POWER BUTTON

This button set the power of module on or off.

2. TEMPO + & -

These buttons are used to change current tempo.

3. MASTER VOLUME + & -

These buttons can be used to change the master volumes.

4. ACC. VOLUME + & -

These buttons can be used to change the accompaniment volumes.

5. REC AND LED INDICATOR

This button can be used to start or stop recording.

6. CLICK AND LED INDICATOR

This button is used to turn on or off the metronome.

7. 3-DIGIT LED

This LED is the main display device of DD315, which will show the parameters of current menu.

8. HAND PERCUSSION AND LED INDICATOR

This button can be used to turn on the hand percussion function.

9. DRUM OFF AND LED INDICATOR

This button is used to enable or disable drum off function.

10. KIT

This button is used to enter kit menu.

11. VOICE

This button is used to enter voice or volume menu.

12. SONG

This button is used to enter song menu.

13. START/STOP

This button can be used to start or stop song playing.

14. VOLUME

This button can be used to change the volume of pad.

15. SELECT + & -

These buttons can be used to change values (kit number, voice number, song number, etc.) when editing.

16. SAVE

This button is used to save current kit settings to a user kit.

17. PAN

This button can be used to change the pan of pad.

18. PLAY/STOP

This button can be used to start or stop recording replay.

Panel Controls

19.REVERB

This button is used to change the reverb level.

20.PAD INDICATORS

Display the pad currently being played.

21.DEMO

This button can be used to start or stop demo song playing.

22.NOTE

This button can be used to change the midi note of pad.

Rear Panel

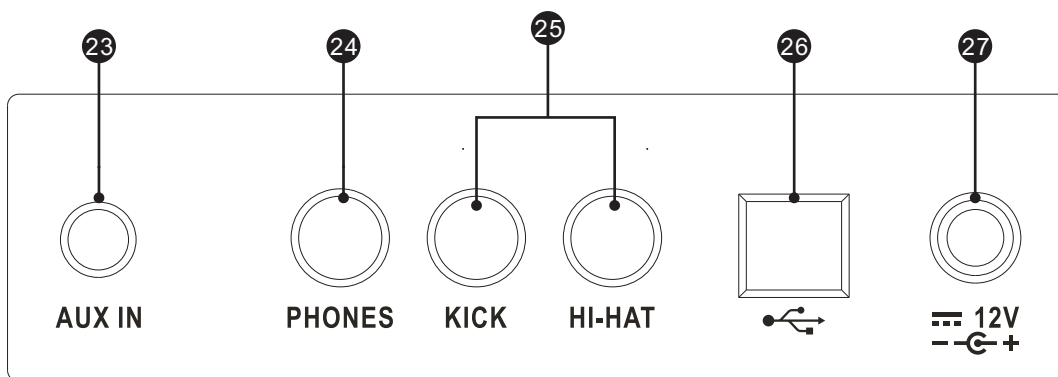

23.AUXIN INPUT

This port is used to connect with the external audio device,like CD player or MP3 player.

24.PHONES JACK

This jack is used to connect with headphones

25.PEDAL INPUT JACKS

Kick and hi-hat pedal input jacks.

26.USB JACK

This port is used to connect with external device.

27.DC INPUT

Connect to a DC 12V.

Select a Drum Kit

Kit menu is the default menu after power on, default values 001.

Press [KIT] button to enter kit menu. The 3-digit LED will show the current kit number with the corresponding menu indicator lit up. The button SELECT [+]/[-] can be used to select any kit (preset kit 1-45, user kit 46-50) as the current kit.

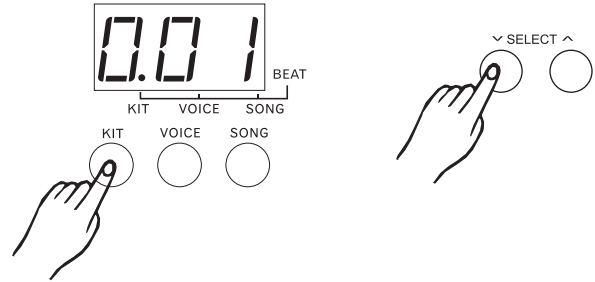

Set Pad Voice

Press [VOICE] button to enter **voice menu**. Default value will be the voice value of the hi-hat pad based on different kit selected. For example, if kit 001 has been selected, then press voice, the value on LED will be 161, which is the voice value of the hi-hat pad.

If **voice menu** is selected the corresponding menu indicator will be lit up.

In this menu, the 3-digit LED will show the voice number of current pad, The button SELECT [+]/[-] can be used to select any voice(1-265, loop) for current pad.

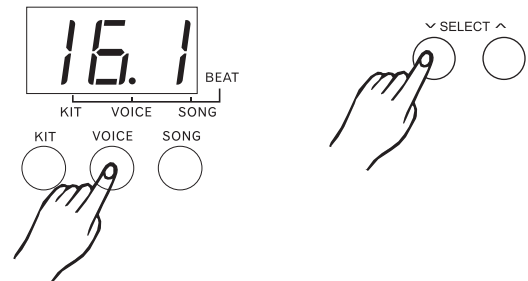

Set pad volume

Press [VOLUME] button to enter voice menu. If voice menu is selected, the corresponding menu indicator will be lit up.

In this menu, the 3-digit LED will show the volume of current pad, which can be selected by pad hitting. The button SELECT [+]/[-] can be used to change the volume (0-31) of the current pad.

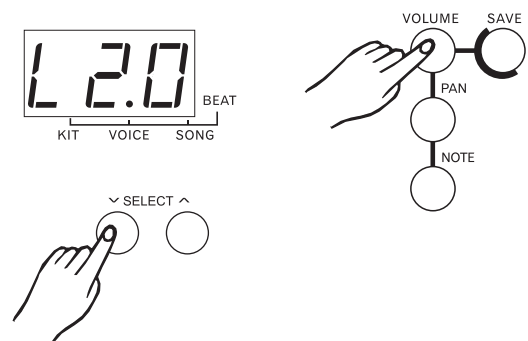

Set pad pan

Press the [PAN] button to enter voice menu. If voice menu is selected, the corresponding menu indicator will be lit up.

In this menu, the 3-digit LED will show the pan of current pad, which can be selected by pad hitting. The button SELECT [+]/[-] can be used to change the pan(-8~+8) of the current pad.

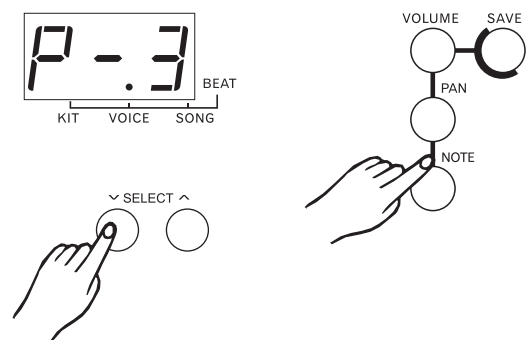

Operation

Set pad midi note

Press [NOTE] button to enter voice menu. If voice menu is selected, the corresponding menu indicator will be lit up.

In this menu, the 3-digit LED will show the midi note of current pad, which can be selected by pad hitting. The button SELECT [+]/[-] can be used to change the midi note (n00-n99, loop) of the current pad.

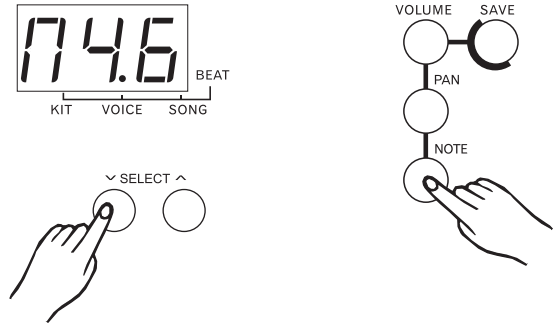

Save Kit

Press [SAVE] button to enter the kit save menu. The button SELECT [+]/[-] can be used to select a user kit (46-50, loop) current kit setting. During kit selecting the user kit number will keep flashing.

Press [SAVE] button again, the current kit setting will be saved to the selected kit. The machine will quit to the kit menu and select this user kit as the current one, if all the data has been saved successfully.

If saving is failed due to error, an "Err" will appear on the LED.

Note: The unsaved kit setting will be lost after kit changing.

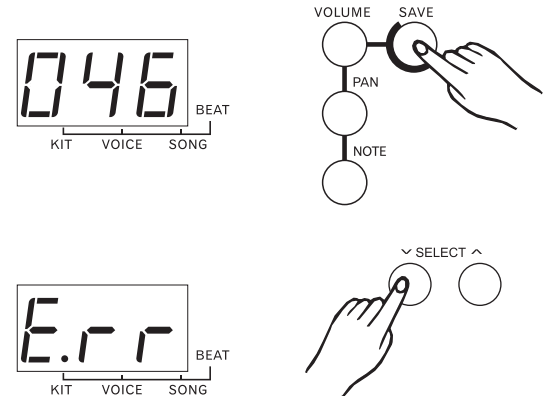

Play Song

Press [SONG] button to enter song menu. Default value is 001, The 3-digit LED will show current song number with corresponding menu indicator lit up. The button SELECT [+]/[-] can be used to select current song (1-100, loop). First 80 styles are loop playing. Press [START/STOP] to start or stop the song player. If song is switched while it's playing, the new song will not start until the end of current measure.

Each song has its own default tempo and drum kit, the song player will initialize the current kit and current tempo at the beginning of song playing.

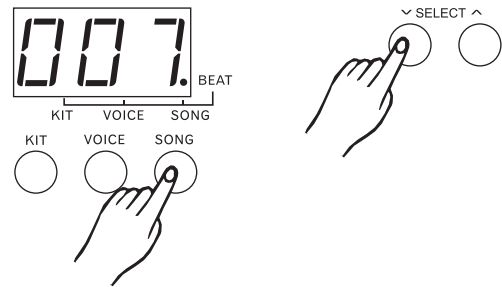

Main Volume

In main volume menu, the digit on far left of LED will display letter "L". The two digits on the right will display current main volume. The button MASTER VOLUME [+]/[-] can be used to adjust the volume (0-16, not loop). And this value will be auto-saved after adjusted.

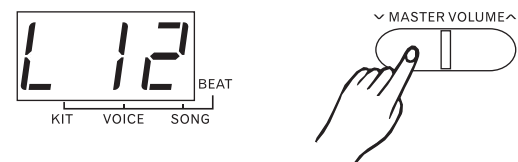

Accompaniment Volume

In accompaniment volume menu, the digit on far left of LED will display letter “A”. The two digits on the right will display current accompaniment volume. The button ACC.VOLUME [+] / [-] can be used to adjust the volume (0-16, not loop). This value will be auto-saved after adjusted.

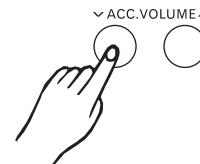

Drum Off

Pressing [DRUM OFF] button will enable or disable the drum off function when a song is playing. If drum off is enabled, the drum voice will be turned off with the drum off indicator lit on. This function is quite useful for practicing. Drum off button cannot be manipulated while play back record.

Note: If you can't play with the song, you can decrease the tempo value, please see the [TEMPO] section.

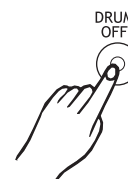

Tempo

Press the TEMPO [+] / [-] button to enter the tempo menu. Button [+] and [-] can be used to change current tempo (30-280, not loop), which affects the speed of clicking, and song playing. Press both [+] and [-] will reset current tempo to its default value (current song tempo).

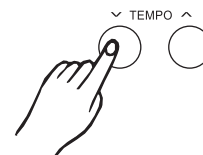

Metronome

Press once on [CLICK] button for human voice counting. Press twice on [CLICK] for clicking sound. Press again to turn off the clicking.

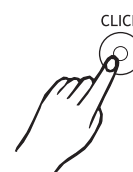

Hand Percussion

Press [HAND PERC] button to enter the hand percussion mode with the hand mode indicator lit up. The song number is 77 and the kit number is 15.

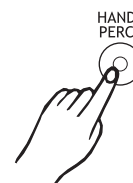

Operation

Demo

Press [DEMO] button to start or stop demo song playing. The 3-digit LED will display "dE", you can also press [START/STOP] button to stop demo song playing.



Reverb

Press [REVERB] button to enter reverb function. In this menu, the digit on far left of LED will display letter "R". The two digits on the right will display current reverb level. The button SELECT [+]/[-] can be used to adjust the reverb level (0-3, not loop). This value will be auto-saved after adjusted.

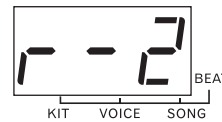

Record

Prepare to Record

Select the desired song, drum kit, tempo, drum off setting, and reverb settings.

Start Recording

Press the [REC] button, the light start flashing. Press the [START/STOP] button or strike the pad, the light stop flashing and the recording process starts.



Stop Recording

To stop recording, press the [START/STOP] button or [REC] button. The record indicator will turn off. If the memory is full, "FL" will appear on the display and recording process stops automatically.

Note: When you start recording, the vocal metronome also starts to count. But the sound of the vocal will not be record. To stop the metronome, press the [CLICK] button.

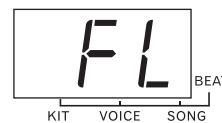

Playback

Press the [PLAY/STOP] button will start or stop playing recorded song.

Note: When you record a new song, it will replace the previous recording. The song data recorded will be lost when you turn off the power.

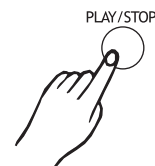

Pedals

this appliance supports 1 hi-hat pedal and 1 kick pedal as input device.

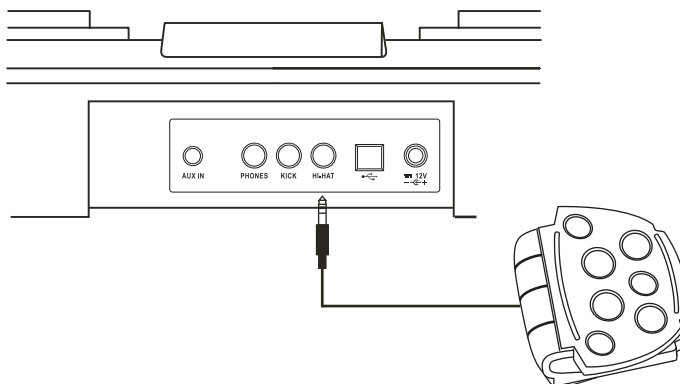

Phones output

The phones output supports a stereo headphone as output device.

Note: the headphone is optional.

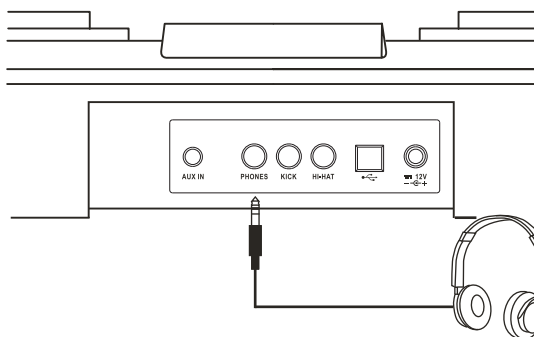

USB jack

This appliance will output all the MIDI codes generated by pads hitting or pedal stepping via the MIDI output connector. clicking and the MIDI codes in songs are excluded. It's also receive the MIDI data from external device.

AUX IN input

For connecting an extra audio player, for example, MP3 and so on via a stereo plug. You can enjoy playing the drum along with your favorite songs.

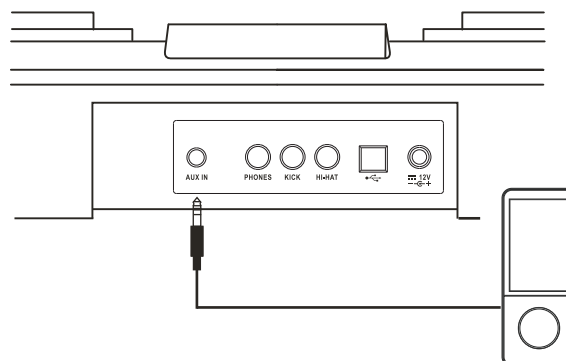

Voice list

NO.	Name
KICK	
1	22" Acoustic Kick
2	24" Standard Kick
3	Brush Kick
4	Rock Kick
5	Jazz Kick
6	Room Kick
7	Fusion Kick
8	1970's Kick
9	Vintage Kick
10	HipHop Kick
11	Reggae Kick
12	Old School Kick
13	Lo-Fi Kick
14	Junkyard Kick
15	Noise Kick
16	Drum & Bass Kick
17	808 Kick
18	909 Kick
19	Electronic Kick 1
20	Dance Kick
21	FX Mix Kick
22	Techno Kick
23	Electronic Kick 2
24	Magic Kick
SNARE	
25	14" Acoustic Snare
26	14" Standard Snare
27	14" Funk Snare
28	Brush Snare
29	14" Jazz Snare
30	14" Rock Snare
31	13" Damped Snare
32	Orchestra Snare
33	Orchestra Snare Rim
34	Room Snare
35	Fusion Snare
36	Big Band Snare
37	Vintage Snare
38	Live Snare
39	Reggae Snare
40	R&B Snare 1
41	808 Snare
42	909 Snare
43	R&B Snare 2
44	Electronic Snare
45	Power Snare
46	Dance Snare
47	Old School Snare
48	House Snare
49	Lo-Fi Snare
50	Junkyard Snare
51	Noise Snare
52	Drum & Bass Snare
53	Techno Snare

54	Techno Snare Rim
55	Magic Snare
56	Acoustic Snare Stick
57	Standard Snare Stick
58	Brush Snare Stick
59	Rock Snare Stick
60	Live Snare Stick
61	Room Snare Stick
62	Fusion Snare Stick
63	Brush Swirl
Tom	
64	Acoustic Tom 1
65	Acoustic Tom 2
66	Acoustic Tom 3
67	Acoustic Tom 4
68	Acoustic Tom 5
69	Acoustic Tom 6
70	Brush Tom 1
71	Brush Tom 2
72	Brush Tom 3
73	Brush Tom 4
74	Brush Tom 5
75	Brush Tom 6
76	Jazz Tom 1
77	Jazz Tom 2
78	Jazz Tom 3
79	Jazz Tom 4
80	Jazz Tom 5
81	Jazz Tom 6
82	808 Tom 1
83	808 Tom 2
84	808 Tom 3
85	808 Tom 4
86	808 Tom 5
87	808 Tom 6
88	909 Tom 1
89	909 Tom 2
90	909 Tom 3
91	909 Tom 4
92	909 Tom 5
93	909 Tom 6
94	Electronic Tom 1
95	Electronic Tom 2
96	Electronic Tom 3
97	Electronic Tom 4
98	Electronic Tom 5
99	Electronic Tom 6
100	Power Tom 1
101	Power Tom 2
102	Power Tom 3
103	Power Tom 4
104	Power Tom 5
105	Power Tom 6
106	Lo-Fi Tom 1
107	Lo-Fi Tom 2
108	Lo-Fi Tom 3

109	Lo-Fi Tom 4
110	Lo-Fi Tom 5
111	Lo-Fi Tom 6
112	Junkyard Tom 1
113	Junkyard Tom 2
114	Junkyard Tom 3
115	Junkyard Tom 4
116	Junkyard Tom 5
117	Junkyard Tom 6
118	Noise Tom 1
119	Noise Tom 2
120	Noise Tom 3
121	Noise Tom 4
122	Noise Tom 5
123	Noise Tom 6
124	Techno Tom 1
125	Techno Tom 2
126	Techno Tom 3
127	Techno Tom 4
128	Techno Tom 5
129	Techno Tom 6
130	Magic Tom 1
131	Magic Tom 2
132	Magic Tom 3
133	Magic Tom 4
Ride	
134	20" Funk Ride
135	808 Ride
136	Ride
137	House Ride
138	Lo-Fi Ride
139	Junkyard Ride
140	Noise Ride
Crash	
141	16" Acoustic Crash
142	16" Acoustic Crash Edge
143	16" Rock Crash
144	16" Rock Crash Edge
145	808Crash
146	909Crash
147	Electronic Crash
148	Brush Crash
149	Lo-Fi Crash
150	China
151	Splash
Hihat	
152	14" Acoustic Hi-hat Close
153	14" Acoustic Hi-hat Open
154	14" Acoustic Hi-hat Edge Close
155	14" Acoustic Hi-hat Edge Open
156	14" Acoustic Hi-hat Pedal
157	14" Acoustic Hi-hat Splash
158	Rock Hi-hat Close
159	Rock Hi-hat Open
160	Fusion Hi-hat Close
161	Fusion Hi-hat Open

162	808 Hi-hat Close
163	808 Hi-hat Open
164	808 Hi-hat Pedal
165	808 Hi-hat Splash
166	909 Hi-hat Close
167	909 Hi-hat Open
168	909 Hi-hat Pedal
169	909 Hi-hat Splash
170	Dance Hi-hat Close
171	Dance Hi-hat Open
172	Dance Hi-hat Pedal
173	Dance Hi-hat Splash
174	Lo-Fi Hi-hat Close
175	Lo-Fi Hi-hat Open
176	Lo-Fi Hi-hat Edge
177	Lo-Fi Hi-hat Pedal
178	Lo-Fi Hi-hat Splash
PERCUSSION 1	
179	Nan Bang
180	Da Mu Yu
181	Xiao Bo
182	Xiao Luo
183	Peng Lin
184	Maracas
185	Metronome Bell
186	Vibra-slap
187	Synthesis Percussion
188	High Q
189	Low Q
190	Mute Hi Conga
191	Open Hi Conga
192	Low Conga
193	High Bongo
194	Low Bongo
195	High Agogo
196	Low Agogo
197	Claves
198	Jingle Bell
199	Cowbell
200	Tambourine
201	Cabasa
202	Long Guiro
203	Short Guiro
204	Vibraphone C3
205	Vibraphone Db3
206	Vibraphone D3
207	Vibraphone Eb3
208	Vibraphone E3
209	Vibraphone F3
210	Vibraphone Gb3
211	Vibraphone G3
212	Vibraphone Ab3
213	Vibraphone A3
214	Vibraphone Bb3
215	Vibraphone B3
216	Vibraphone C4

Voice List

217	Vibraphone Db4
218	Vibraphone D4
219	Vibraphone Eb4
220	Vibraphone E4
221	Vibraphone F4
222	Vibraphone Gb4
223	Vibraphone G4
224	Vibraphone Ab4
225	Vibraphone A4
226	Vibraphone Bb4
227	Vibraphone B4
228	Vibraphone C5
229	Vibraphone Db5

230	Vibraphone D5
231	Vibraphone Eb5
232	Vibraphone E5
233	Vibraphone F5
234	Vibraphone Gb5
235	Vibraphone G5
236	Vibraphone Ab5
237	Vibraphone A5
238	Vibraphone Bb5
239	Vibraphone B5
240	Vibraphone C6
241	Orchestra Timp C2
242	Orchestra Timp Db2

243	Orchestra Timp D2
244	Orchestra Timp Eb2
245	Orchestra Timp E2
246	Orchestra Timp F2
247	Orchestra Timp Gb2
248	Orchestra Timp G2
249	Orchestra Timp Ab2
250	Orchestra Timp A2
251	Orchestra Timp Bb2
252	Orchestra Timp B2
253	Orchestra Timp C3
254	Orchestra Timp Db3
255	Orchestra Timp D3

256	Orchestra Timp Eb3
257	Orchestra Timp E3
258	Orchestra Timp F3
259	Orchestra Timp Gb3
260	Orchestra Timp G3
261	Orchestra Timp Ab3
262	Orchestra Timp A3
263	Orchestra Timp Bb3
264	Orchestra Timp B3
265	Orchestra Timp C4

Kit List

NO.	Name
1	Standard
2	Hard Rock
3	Ballad
4	Acoustic
5	Funk Band
6	Funk
7	Jazz Brush
8	Dance
9	Rock
10	Jazz
11	808
12	909
13	Latin
14	Room
15	Percussion 1
16	Metal
17	Vibraphone
18	Electronic
19	Reggae
20	Fusion 1
21	Drum & Bass
22	Pop
23	Brush
24	World
25	Orchestra

26	Ska
27	Songo
28	Lo-Fi
29	1970's
30	HipHop
31	Big Band
32	Old School
33	R&B
34	Magic
35	Live
36	House
37	Jazz Latin
38	Fusion 2
39	Percussion 2
40	Teckno
41	Vintage
42	Junkyard
43	Noise
44	Studio 1
45	Studio 2
46	User 1(Standard)
47	User 2(Hard Rock)
48	User 3(Ballad)
49	User 4(Acoustic)
50	User 5(Funk Band)

Song List

NO.	Name
1	BluesFunk
2	NuJazzFunk
3	funk1
4	funk2
5	funk3
6	funk4
7	pop funk1
8	pop funk2
9	RetroFunk
10	Fusion1
11	Fusion2
12	Fusion3
13	Fusion4
14	Fusion5
15	Fusion6
16	CoolJazz
17	BigBand1
18	BigBand2
19	BigBand3
20	BigBand4
21	Swing
22	Bebop
23	3/4 jazz
24	Jazz
25	latin jazz1
26	latin jazz2
27	Dance 1
28	DiscoHouse
29	Trance
30	TripHop
31	DrumNBass
32	BreakBeat1
33	Dancefunk
34	Hiphop
35	Dance2
36	D N'B1
37	D N'B2
38	Break beat2
39	ClassicRock
40	HeavyRock
41	RockBallad
42	RockNRoll
43	Punk
44	Rock
45	80's Metal
46	Shuffle
47	60's rock
48	Smaba1
49	BossaNova
50	Salsa
51	Ska
52	Reggae1
53	Reggae2
54	Reggae3
55	LatinRock1

56	LatinRock2
57	Mambo
58	Samba2
59	Latin pop
60	Gtr Bossa
61	LatinDance1
62	LatinDance2
63	R&B1
64	R&B2
65	JazzyFunk
66	Blues
67	Country
68	CountryPop
69	Country Blues
70	Ballad 1
71	BritPop
72	8BeatPop1
73	60'sPop
74	8 Beat 1
75	8 Beat 2
76	8 beat ballad 1
77	8 beat ballad 2
78	16 beat ballad 1
79	16 beat ballad 2
80	world
81	funk1
82	funk2
83	modern jazz
84	big band
85	swing
86	slow fusion
87	country
88	latinjazz
89	reggae
90	latin
91	boogie
92	disco
93	d n'b
94	metal
95	hardrock
96	8 beat 1
97	8 beat 2
98	16 beat 1
99	funk 3
100	funk 4

MIDI Implementation Chart

Function		Transmitted	Recognized	Remarks
Basic Channel	Default Changed	10ch ×	1-16ch ×	
Mode	Default Messages Altered	×	1 ×	
Note Number : True voice		27-88 *****	0—127 0—127	
Velocity : Note on Note off		○ 9nH,V=1-127 × (9nH,V=0)	○ 9nH,V=1-127 × (9nH,V=0; 8nH,V=0-127)	
After Touch	key's Ch's	×	×	
Pitch Bend		×	○	
Control	0 1 5 7 10 11 20 64 65 66 67 80 81 91 93 120 121 123	×	○	Bank select Modulation Portamento time Volume Pan Expression Rhythm allocation Sustain Pedal Portamento on/off Sostenuto Pedal Soft Pedal Reverb Program Chorus Program Reverb level Chorus level All Sound Off Reset all controllers All notes off
Program Change : true		×	○ 0—127	
System Exclusive		*****	○	
System : Song Position : Song Select Common : Tune		×	×	
System : Song Position : Song Select Common : Tune		×	×	
System : Clock Real Time : Commands : Start : Stop		×	×	
Aux : LOCAL ON/OFF : All Notes Off Messages : Active sense : Reset		×	×	

Mode 1: OMNI ON , POLY
Mode 3: OMNI OFF , POLY

Mode 2: OMNI ON , MONO
Mode 4: OMNI OFF , MONO

○ : YES
× : NO

Specifications

Main features:	7 drum pads with touch sensitivity and two pedals (kick and hi-hat)
	3-digit LED displays
	1 phones output and 1 USB jack (MIDI IN/OUT).
	45 preset drum kits,5 user drum kits.
	265 percussion voices and 128 GM voices, 16M bytes voice data
	100 songs (include 80 styles and 20 songs).
	1 demo song
	1 track recording
Hand-percussion:	use your hand to strike pads.
Metronome:	2 different voices.
Dimensions:	500(L)×370(W)×157.4(H)mm
Net Weight:	3.3kg

*Specifications may be changed or modified at any time without prior notice